

SPECIFICATION

DEVICE NAME : Power MOSFET

TYPE NAME : 2SK2832-01

SPEC. No. :

This material and the information herein is the property of Fuji Electric Co., Ltd. They shall be neither reproduced, copied, lent, or disclosed in any way whatsoever for the use of any third party nor used for the manufacturing purposes without the express written consent of Fuji Electric Co., Ltd.

Fuji Electric Co., Ltd.
Matsumoto Factory

This Specification is subject to change without notice.

	DATE	NAME	APPROVED	Fuji Electric Co., Ltd.	
DRAWN				DWG. NO.	1/11
CHECKED					

H04-004-07

1. Scope
This specifies Fuji power MOSFET 2SK2832-01
2. Construction N-channel enhancement mode power MOSFET
3. Application for switching
4. Outview T0-220 Outview See to 5/11 page
5. Absolute maximum ratings at $T_c=25^\circ\text{C}$ (unless otherwise specified)

Description	Symbol	Characteristics	Unit	
Drain-source voltage	V_{DS}	60	V	
Drain-gate voltage	V_{DGR}	60	V	$R_{GS}=20\text{ k}\Omega$
Continuous Drain current	I_D	± 50	A	
Pulsed drain current	I_{DPulse}	± 200	A	
Gate-source voltage	V_{GS}	± 20	V	
Maximum power dissipation	P_D	80	W	
Operating and storage temperature range	T_{ch}	150	$^\circ\text{C}$	
	$T_{stg.}$	-55 ~ +150	$^\circ\text{C}$	

6. Electrical characteristics at $T_c=25^\circ\text{C}$ (unless otherwise specified)
Static ratings

Description	Symbol	Conditions	Characteristics			Unit
			Min.	Typ.	Max.	
Drain-source breakdown voltage	$B V_{DSS}$	$I_D = 1\text{mA}$ $V_{GS} = 0\text{V}$	60			V
Gate threshold voltage	$V_{GS(th)}$	$I_D = 1\text{mA}$ $V_{DS} = V_{GS}$	1.0	1.5	2.0	V
Zero gate voltage drain current	I_{DSS}	$V_{DS} = 60\text{V}$ $V_{GS} = 0\text{V}$	$T_{ch} = 25^\circ\text{C}$	10	500	μA
	I_{DSS}		$T_{ch} = 125^\circ\text{C}$	0.2	1.0	mA
Gate-source leakage current	I_{GSS}	$V_{GS} = \pm 20\text{V}$ $V_{DS} = 0\text{V}$		10	100	nA
Drain-source on-state resistance	$R_{DS(on)}$	$I_D = 25\text{A}$	$V_{GS} = 4\text{V}$	22	34	m Ω
			$V_{GS} = 10\text{V}$	14	20	

Fuji Electric Co., Ltd

DWG.NO.

2/11

H04-004-03

Dynamic ratings

Description	Symbol	Conditions	Characteristics			Unit
			Min.	Typ.	Max.	
Forward transconductance	g_{fs}	$I_D = 25A$ $V_{DS} = 25V$	17	35		S
Input capacitance	C_{iss}	$V_{DS} = 25V$ $V_{GS} = 0V$ $f = 1MHz$		3100	4650	pF
Output capacitance	C_{oss}			920	1380	pF
Reverse transfer capacitance	C_{rss}			370	560	pF
Turn-on time	$t_{d(on)}$	$V_{CC} = 30V$ $V_{GS} = 10V$ $I_D = 50A$ $R_{GS} = 10\Omega$		15	30	ns
	t_r			40	60	ns
Turn-off time	$t_{d(off)}$			180	270	ns
	t_f			100	150	ns

Reverse diode

Description	Symbol	Conditions	Characteristics			Unit
			Min.	Typ.	Max.	
Avalanche capability	I_{AV}	$L = 100\mu H$, $T_{ch} = 25^\circ C$ *See Fig.1 and 2	50.0			A
Diode forward on-voltage	V_{SD}	$I_F = 2 \times I_{DR}$ $V_{GS} = 0V$, $T_{ch} = 25^\circ C$		1.3	1.9	V
Reverse recovery time	t_{rr}	$I_F = I_{DR}$ $V_{GS} = 0V$ $-di_F/dt = 100A/\mu s$ $T_{ch} = 25^\circ C$		70		ns
Reverse recovery charge	Q_{rr}			110		μC

7. Thermal resistance

Description	Symbol	Conditions	Characteristics			Unit
			Min.	Typ.	Max.	
Thermal resistance	$R_{th_{ch-c}}$				1.56	$^\circ C/W$
	$R_{th_{ch-a}}$				125	$^\circ C/W$

This material and the information herein is the property of Fuji Electric Co., Ltd. They shall be neither reproduced, copied, lent, or disclosed in any way whatsoever for the use of any third party nor used for the manufacturing purposes without the express written consent of Fuji Electric Co., Ltd.

Fig.1 Test circuit

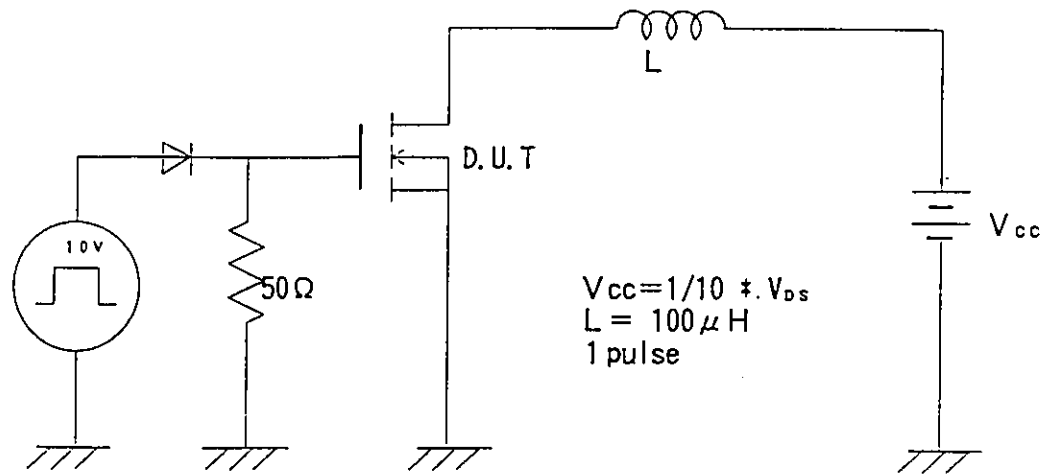
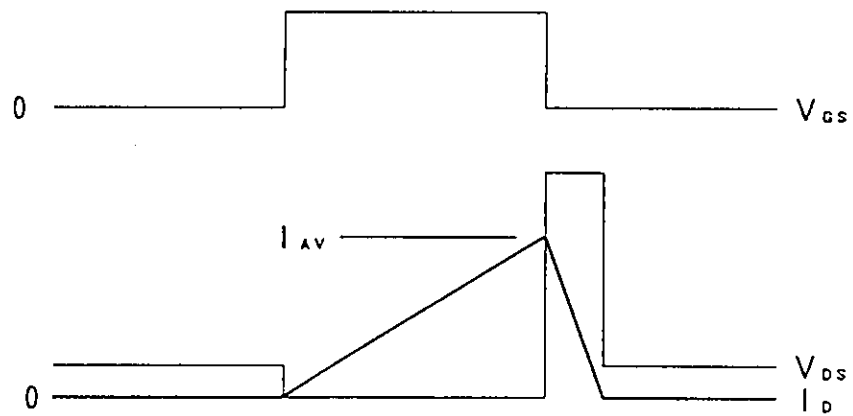
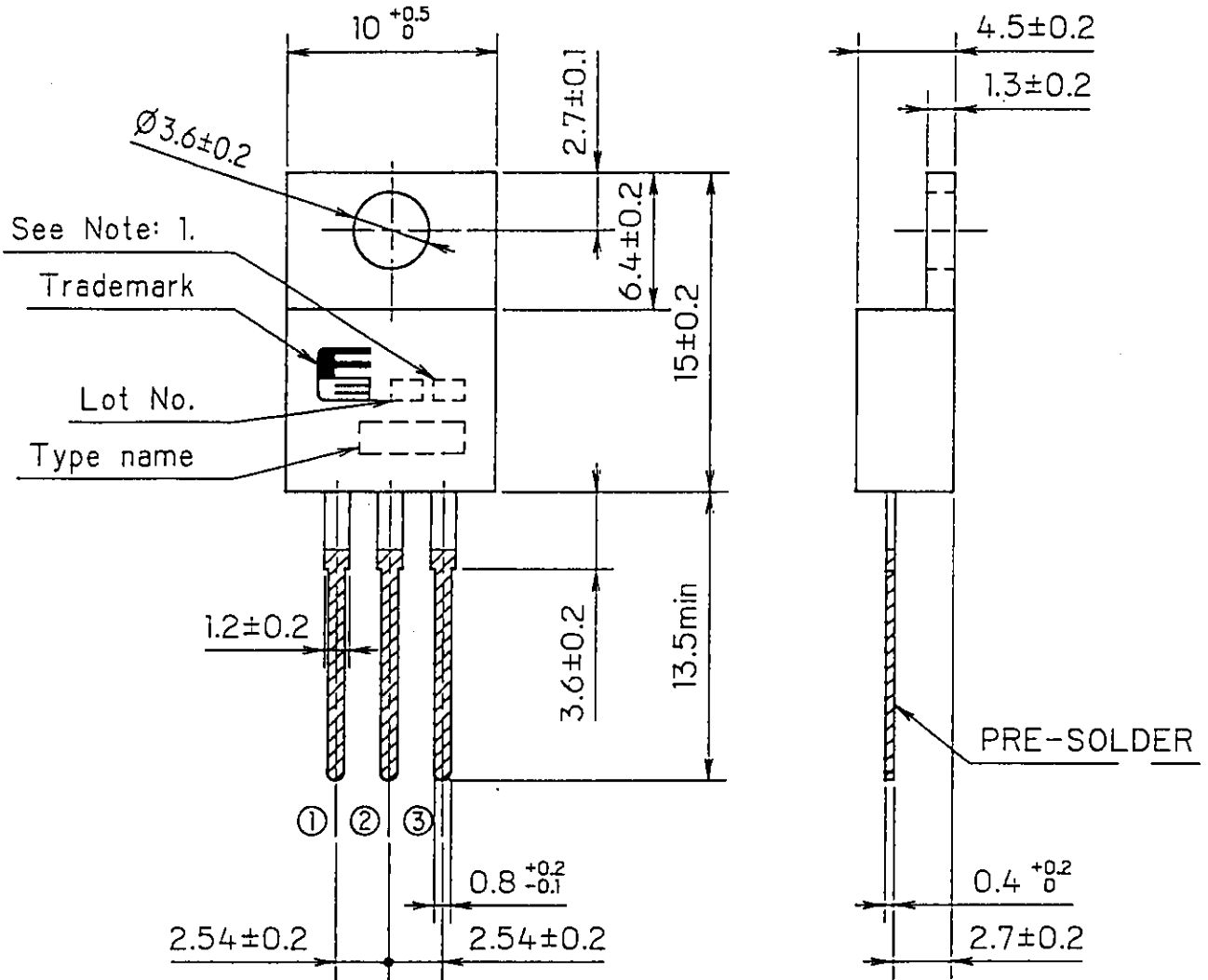

Fig.2 Operating waveforms



FUJI POWER MOS FET

TYPE : _____



This material and the information herein is the property of Fuji Electric Co. Ltd. They shall be neither reproduced, copied, lent, or disclosed in any way whatsoever for the use of any third party nor used for the manufacturing purposes without the express written consent of Fuji Electric Co. Ltd.

See Note: 1.

Trademark

Lot No.

Type name

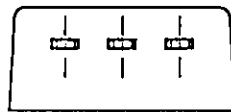

① ② ③

CONNECTION

- ① GATE
- ② DRAIN
- ③ SOURCE

Note: 1. $V_{GS(th)}$ selected code.

Note: 1. Guaranteed mark of avalanche ruggedness.

JEDEC : TO-220AB

DIMENSIONS ARE IN MILLIMETERS.

Fuji Electric Co., Ltd

DWG. NO.

5/11

H04-004-03

Power Dissipation
 $PD=f(T_c)$

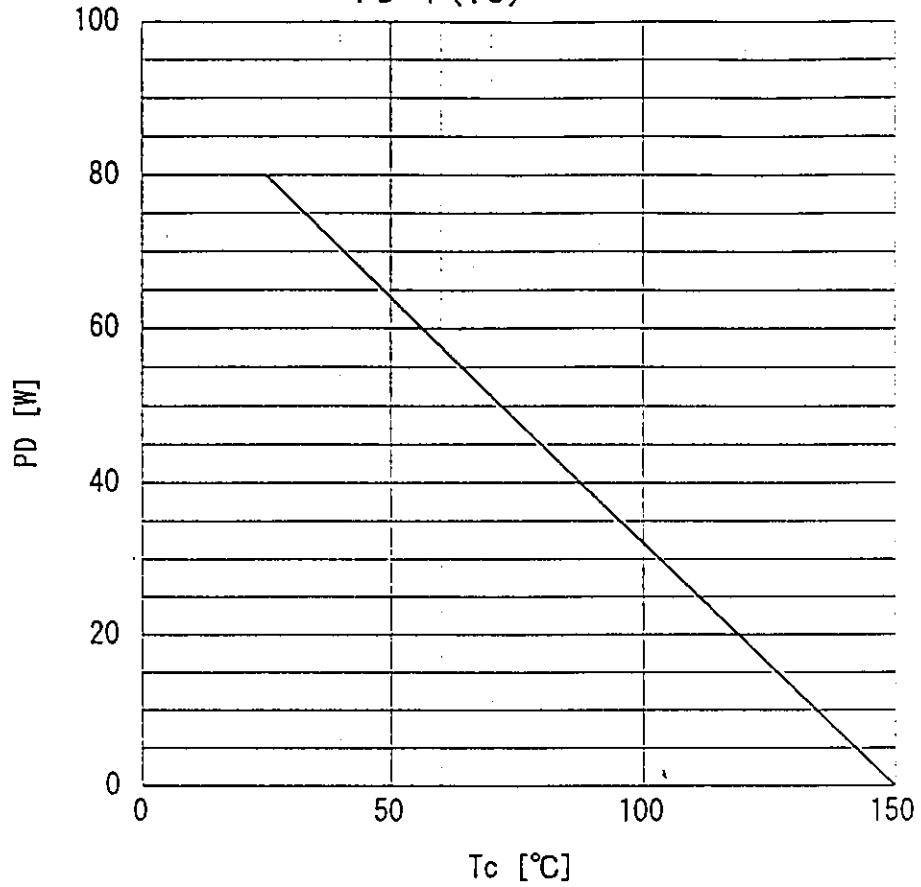

Safe operating area
 $ID=f(V_{DS}) : D=0.01, T_c=25^\circ\text{C}$

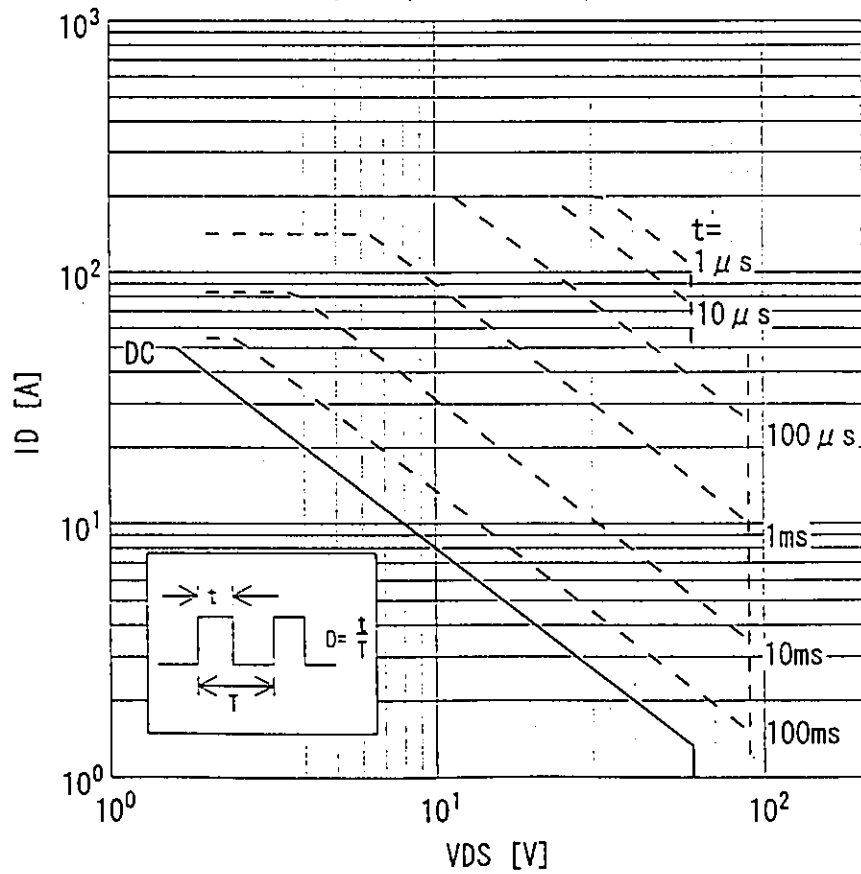

Typical output characteristics
 $I_D = f(V_{DS}) : 80 \mu s$ pulse test, $T_c = 25^\circ C$

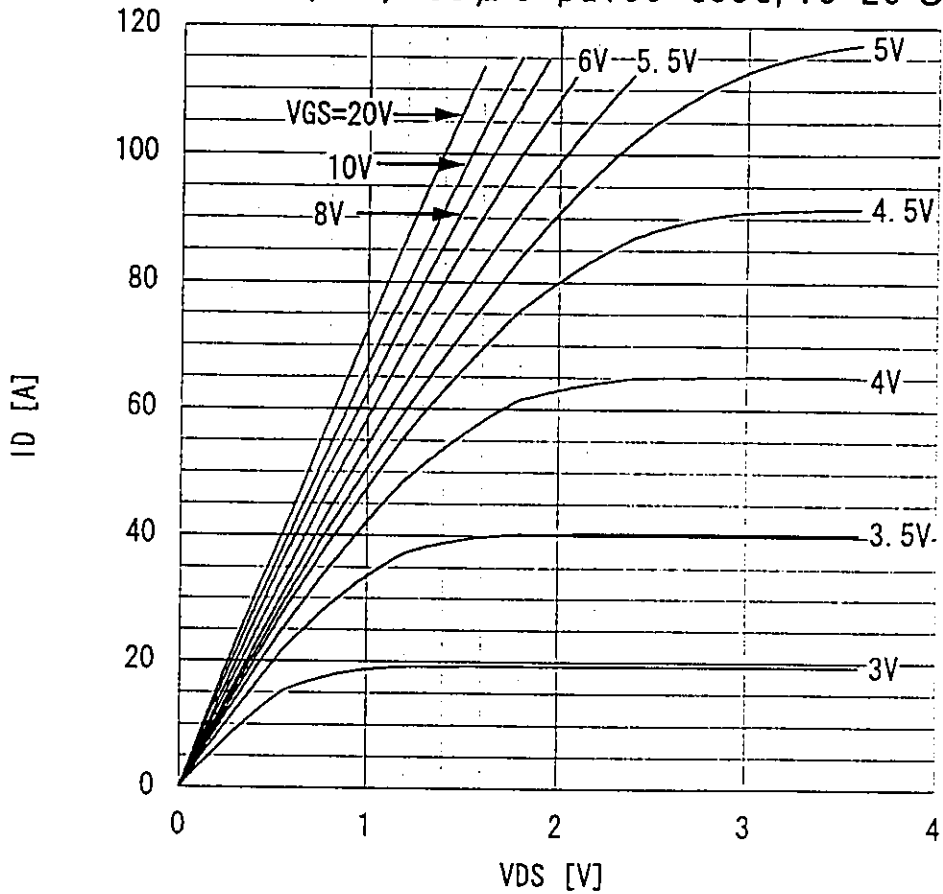

Typical transfer characteristic
 $I_D = f(V_{GS}) : 80 \mu s$ pulse test, $V_{DS} = 25V$, $T_{ch} = 25^\circ C$

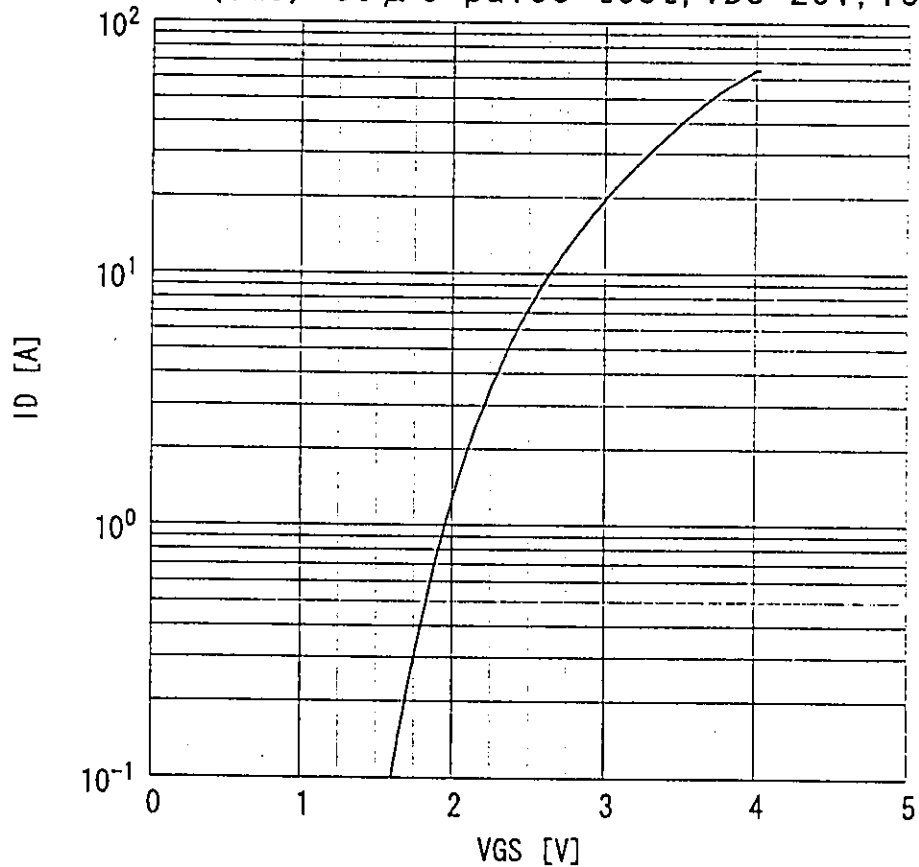

Typical forward transconductance
 $g_{fs}=f(I_D)$: $80\ \mu\text{s}$ pulse test, $V_{DS}=25\text{V}$, $T_{ch}=25^\circ\text{C}$

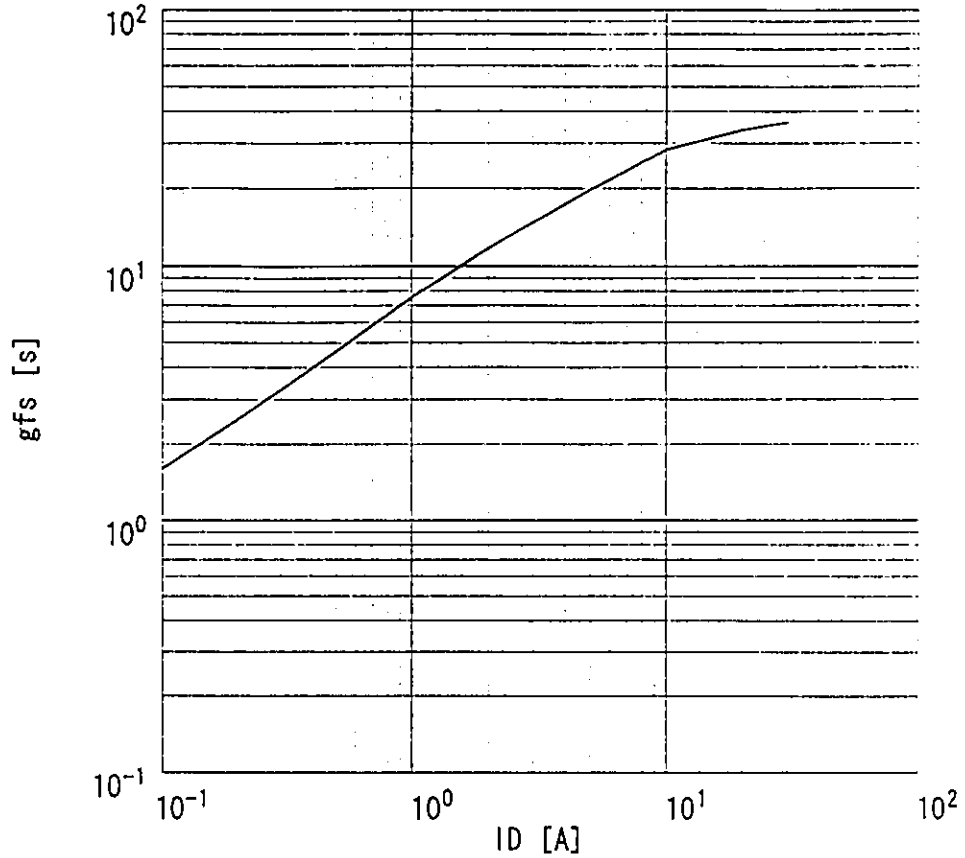

Typical drain-source on-state resistance
 $R_{DS(on)}=f(I_D)$: $80\ \mu\text{s}$ pulse test, $T_c=25^\circ\text{C}$

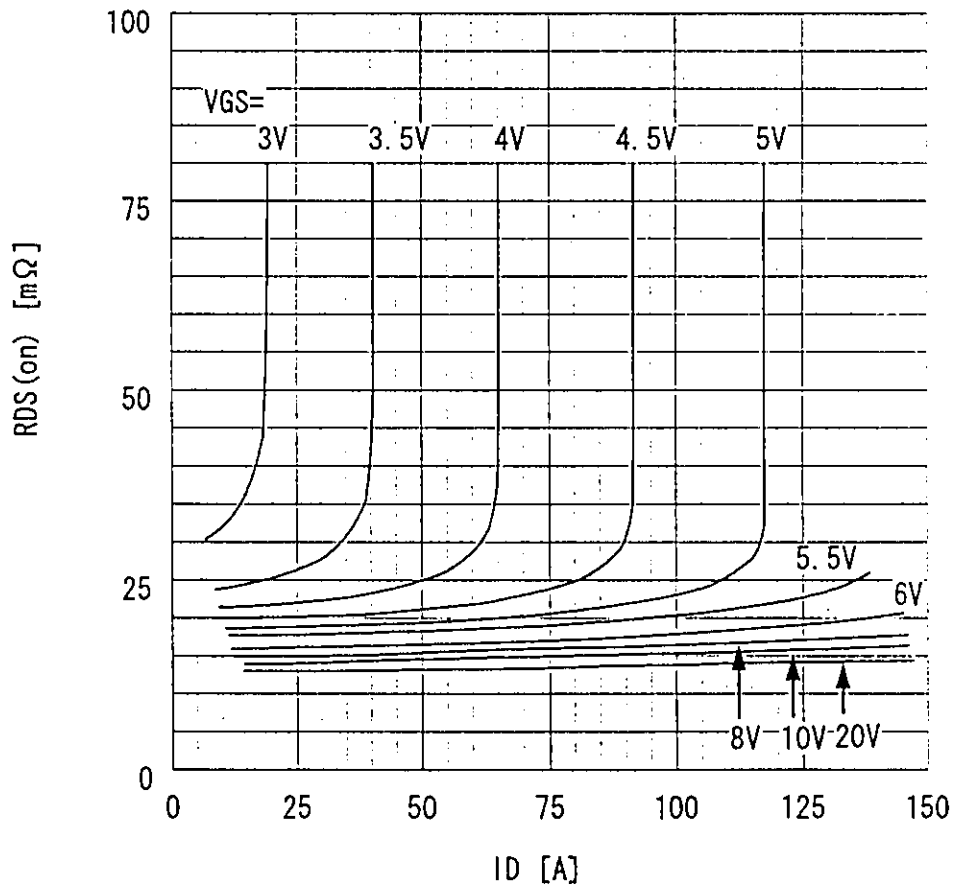

Drain-source on-state resistance
 $R_{DS(on)} = f(T_{ch}) : I_D = 25A, V_{GS} = 10V$

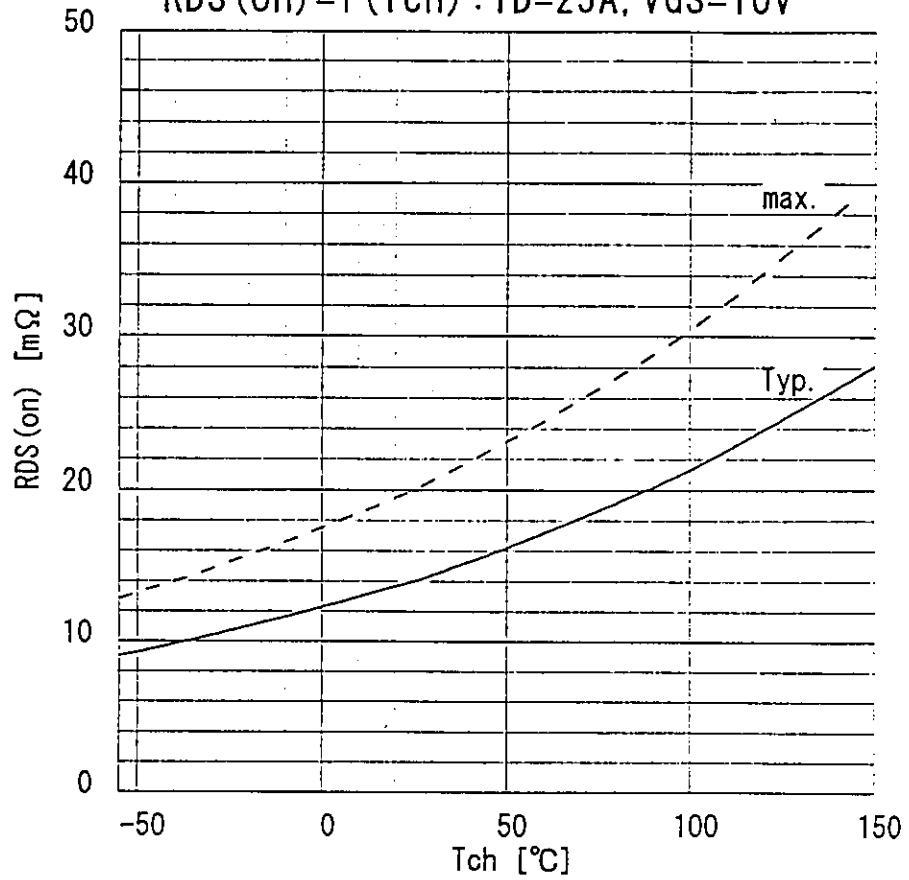

Gate threshold voltage
 $V_{GS(th)} = f(T_{ch}) : I_D = 1mA, V_{DS} = V_{GS}$

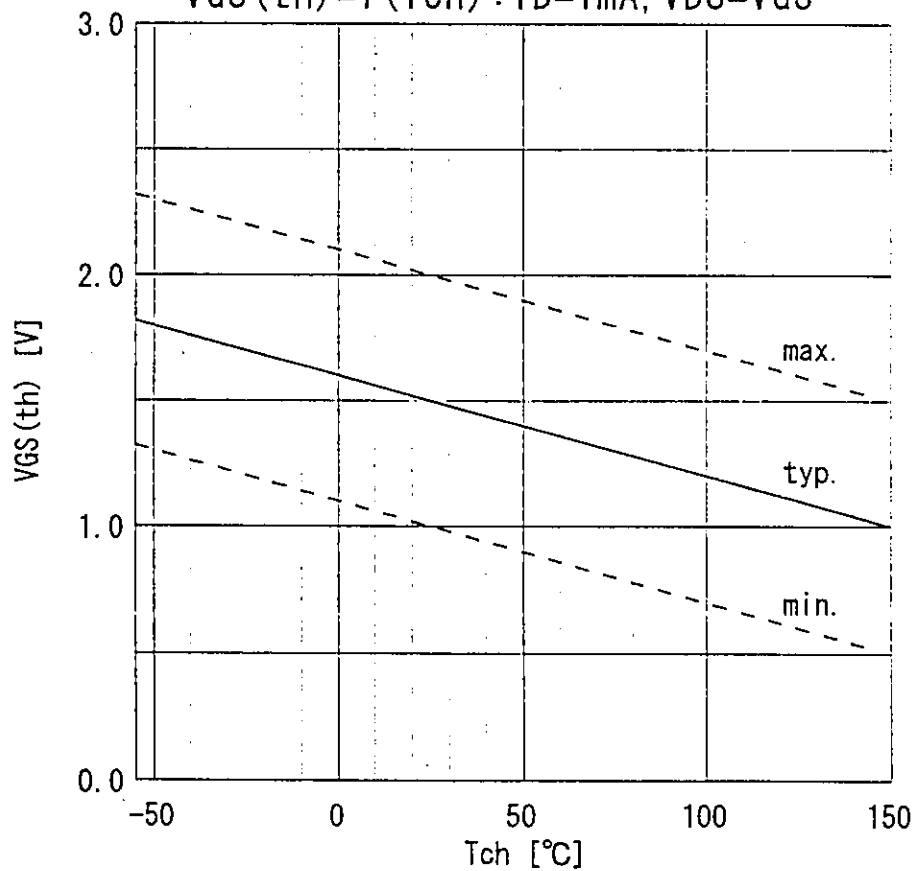

Typical gate charge characteristic
 $V_{GS} = f(Q_g) : I_D = 50A, T_c = 25^\circ C$

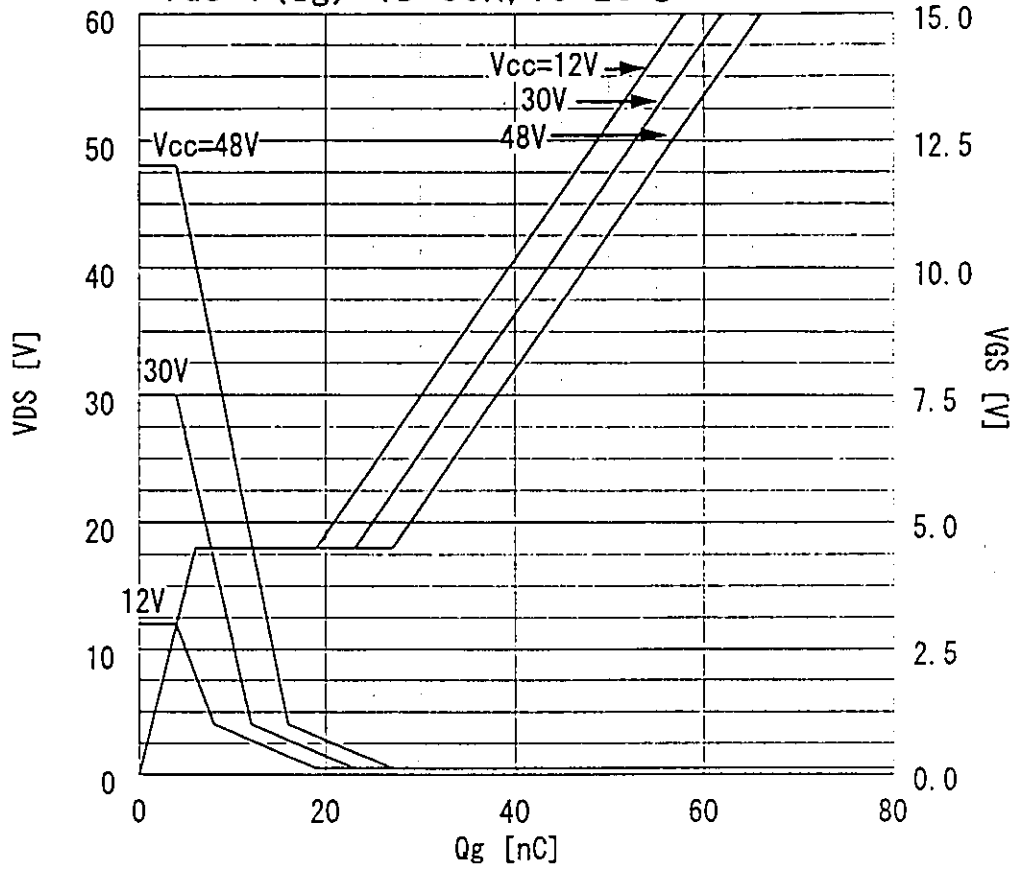

Typical capacitances
 $C = f(V_{DS}) : V_{GS} = 0V, f = 1MHz$

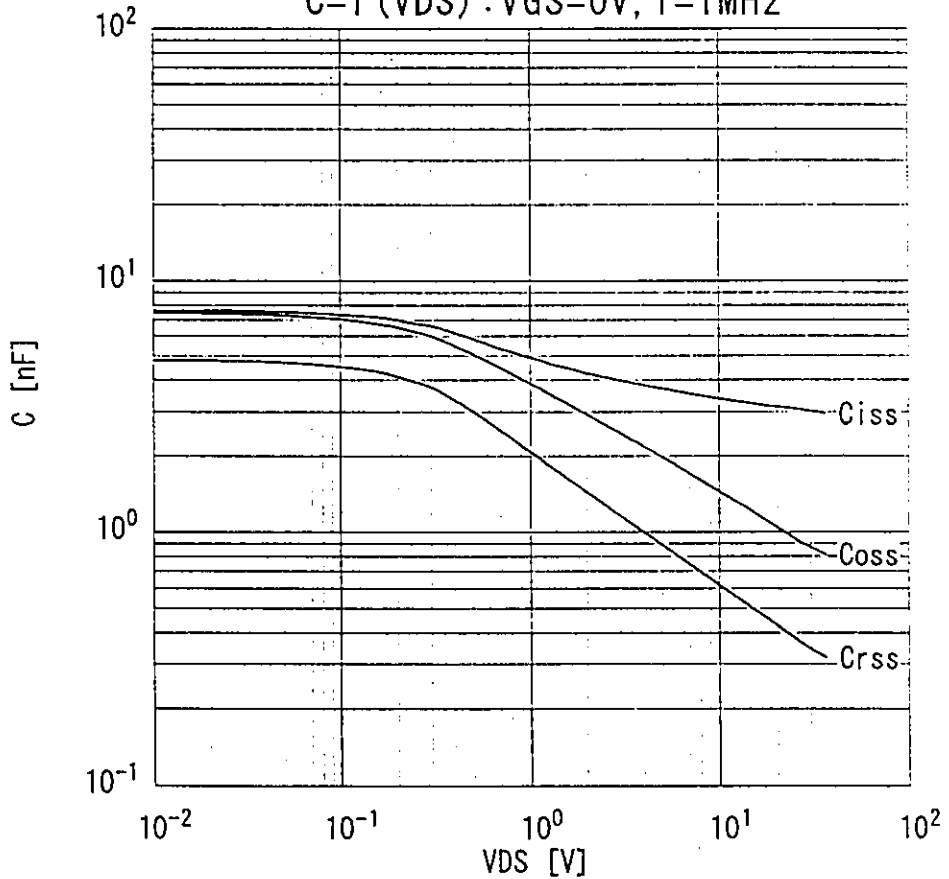

Forward characteristic of reverse diode

$I_F = f(V_{SD}) : 80 \mu s$ pulses test, $V_{GS} = 0V$

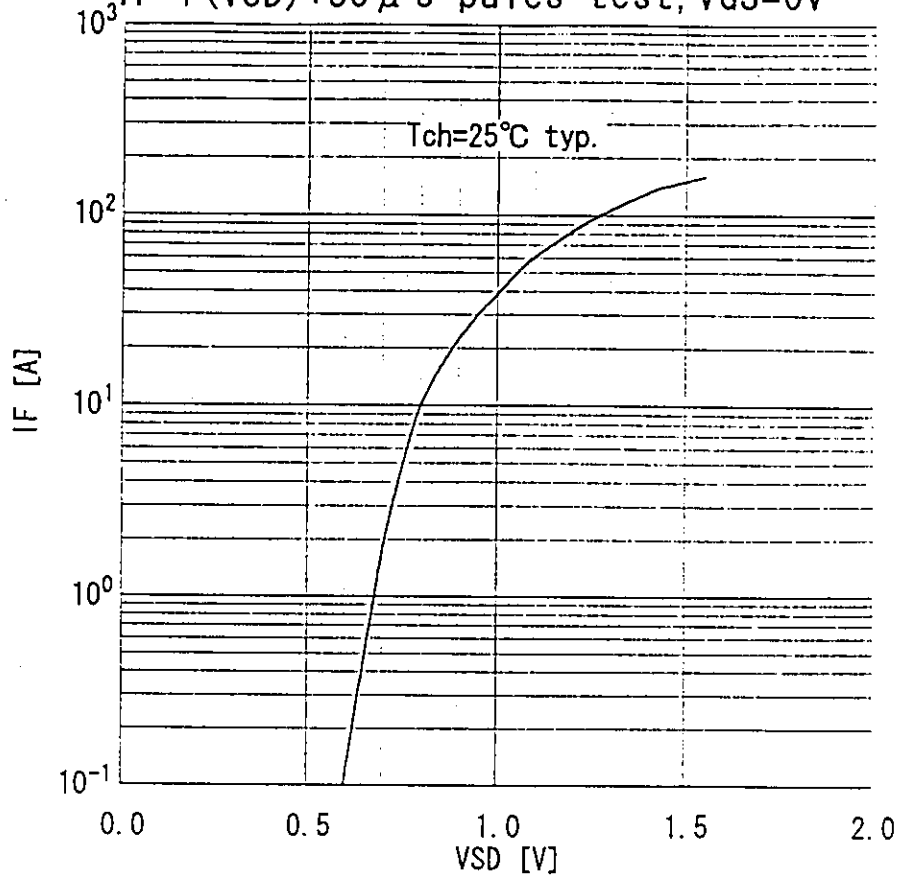

Transient thermal impedance

$Z_{thch} = f(t)$ parameter: $D = t/T$

