

> **Features**

- Include Fast Recovery Diode
- High Voltage
- Low Driving Power

> **Applications**

- Motor Control
- Inverters
- Choppers

> **Outline Drawing**

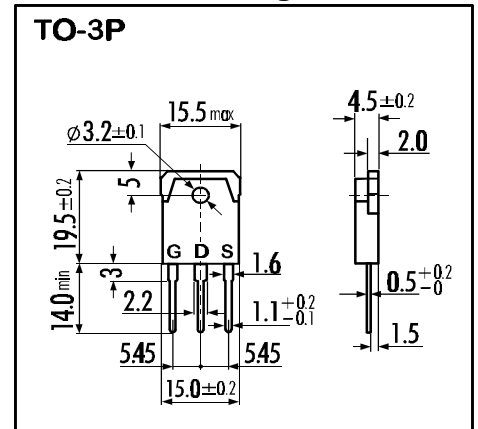

> **Maximum Ratings and Characteristics**

- Absolute Maximum Ratings (T_C=25°C), unless otherwise specified

Item	Symbol	Rating	Unit
Drain-Source-Voltage	V _{DS}	250	V
Continuous Drain Current	I _D	30	A
Pulsed Drain Current	I _{D(puls)}	120	A
Continuous Reverse Drain Current	I _{DR}	30	A
Gate-Source-Voltage	V _{GS}	±20	V
Max. Power Dissipation	P _D	150	W
Operating and Storage Temperature Range	T _{ch}	150	°C
	T _{stg}	-55 ~ +150	°C

> **Equivalent Circuit**

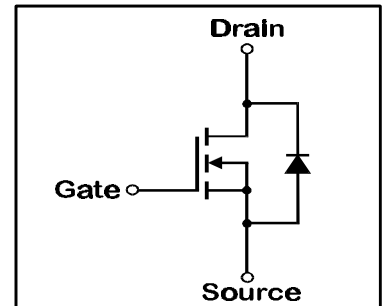

- Electrical Characteristics (T_C=25°C), unless otherwise specified

Item	Symbol	Test conditions	Min.	Typ.	Max.	Unit
Drain-Source Breakdown-Voltage	V _{(BR)DSS}	I _D =1mA V _{GS} =0V	250			V
Gate Threshold Voltage	V _{GS(th)}	I _D =10mA V _{DS} =V _{GS}	2,1	3,0	4,0	V
Zero Gate Voltage Drain Current	I _{DSS}	V _{DS} =250V T _{ch} =25°C V _{GS} =0V		10	500	μA
Gate Source Leakage Current	I _{GSS}	V _{GS} =±20V V _{DS} =0V		10	100	nA
Drain Source On-State Resistance	R _{DS(on)}	I _D =15A V _{GS} =10V		0,09	0,12	Ω
Forward Transconductance	g _{fs}	I _D =15A V _{DS} =25V	10	20		S
Input Capacitance	C _{iss}	V _{DS} =25V		2400	3600	pF
Output Capacitance	C _{oss}	V _{GS} =0V		500	750	pF
Reverse Transfer Capacitance	C _{rss}	f=1MHz		280	420	pF
Turn-On-Time t _{on} (t _{on} =t _{d(on)} +t _r)	t _{d(on)}	V _{CC} =150V		35	50	ns
	t _r	I _D =30A		140	210	ns
Turn-Off-Time t _{off} (t _{off} =t _{d(off)} +t _f)	t _{d(off)}	V _{GS} =10V		420	630	ns
	t _f	R _{GS} =25 Ω		180	270	ns
Diode Forward On-Voltage	V _{SD}	I _F =I _{DR} V _{GS} =0V T _{ch} =25°C		0,9	1,8	V
Reverse Recovery Time	t _{rr}	I _F =I _{DR} V _{GS} =0V		100	150	ns
		-di _F /dt=100A/μs T _{ch} =25°C				

- Thermal Characteristics

Item	Symbol	Test conditions	Min.	Typ.	Max.	Unit
Thermal Resistance	R _{th(ch-a)}	channel to air			35	°C/W
	R _{th(ch-c)}	channel to case			0,83	°C/W

> Characteristics

Typical Output Characteristics

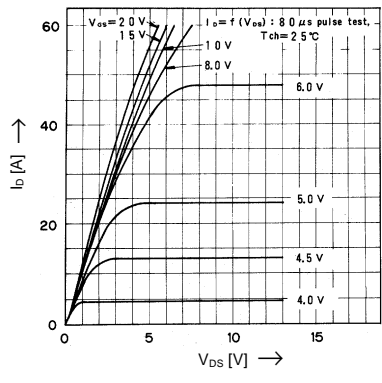

Drain-Source-On-State Resistance vs. T_{ch}

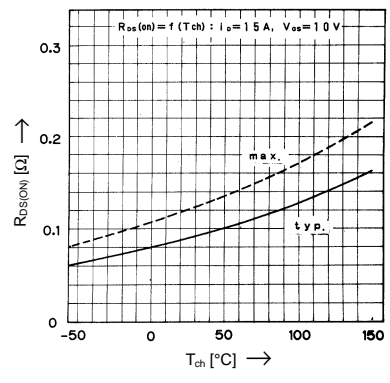

Typical Transfer Characteristics

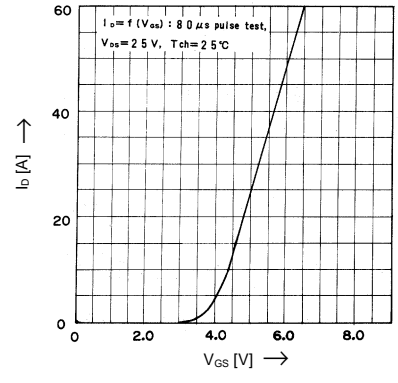

Typical Drain-Source-On-State-Resistance vs. I_D

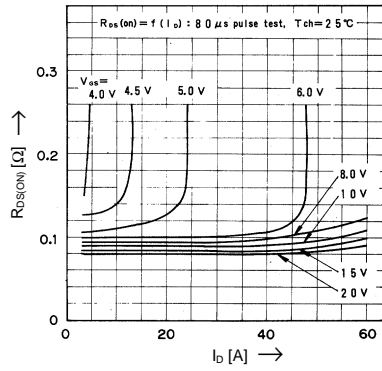

Typical Forward Transconductance vs. I_D

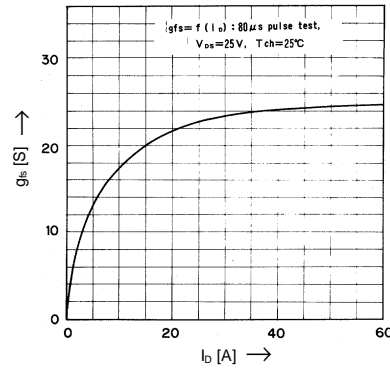

Gate Threshold Voltage vs. T_{ch}

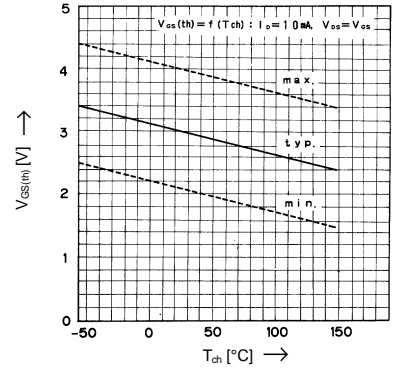

Typical Capacitance vs. V_{DS}

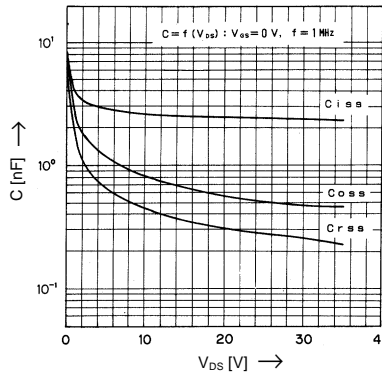

Typical Input Charge

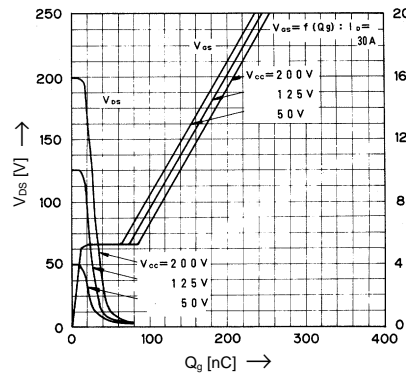

Forward Characteristics of Reverse Diode

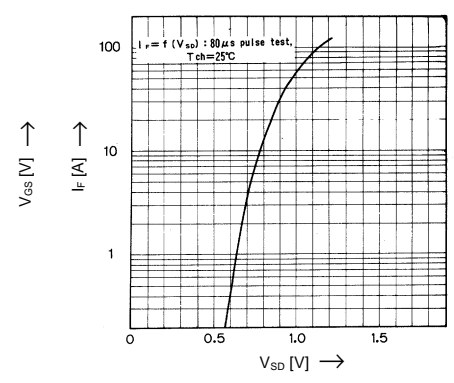

Allowable Power Dissipation vs. T_c

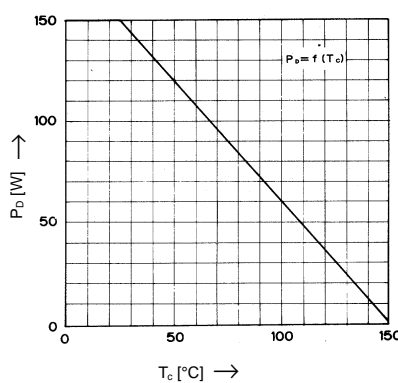

Safe operation area

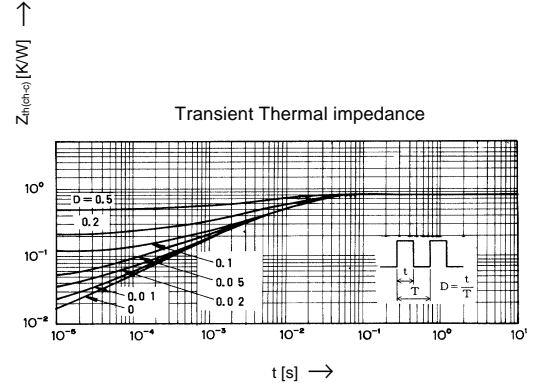
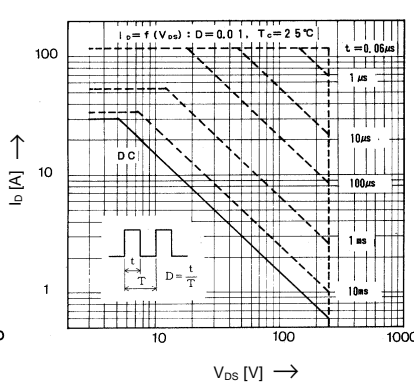

This specification is subject to change without notice!