

SPECIFICATION

DEVICE NAME : IGBT

TYPE NAME : 1MBH20D-060

SPEC. No. : MS5F 4086

DATE : July-15-1997

Fuji Electric Co., Ltd.
Matsumoto Factory

	DATE	NAME	APPROVED	Fuji Electric Co., Ltd.	
DRAWN	July-15-1997	T. Sawada		DWG. NO.	MS5F4086
CHECKED	July-15-1997	T. Agarashi			

Revised Records

Date	Classi- fication	Ind.	Content	Applied date	Drawn	Checked	Approved
July- 15-1997	enactment	—	—————	Issued date	—	<i>J. J. Jelle</i>	

This material and the information herein is the property of Fuji Electric Co., Ltd. They shall be neither reproduced, copied, lent, or disclosed in any way whatsoever for the use of any third party nor used for the manufacturing purposes without the express written consent of Fuji Electric Co., Ltd.

▪ Scope

This specification is applied to Fuji discrete IGBT 1MBH20D-060
supplied for Rockwell Automation Co.,Ltd.

▪ Construction

1. Package dimension
There is a package dimension in 4/14 page .
2. Outview
There are no remarkable flaws on a product .
3. Indication
 - ① Trademark
 - ② Type Name
 - ③ Lot No.

▪ Ratings and Characteristics

1. There are some ratings and characteristics tables in 4/14 page and 5/14 page .
2. There are some performance curves in from 6/14 page to 14/14 page .

▪ Packing

Packing style follows our packing specification MS5Q0026 .

This material and the information herein is the property of Fuji Electric Co.Ltd. They shall be neither reproduced, copied, lent, or disclosed in any way whatsoever for the use of any third party nor used for the manufacturing purposes without the express written consent of Fuji Electric Co., Ltd.

Ratings and characteristics of Fuji IGBT

1MBH20D-060

1. Outline Drawing

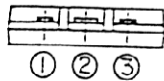
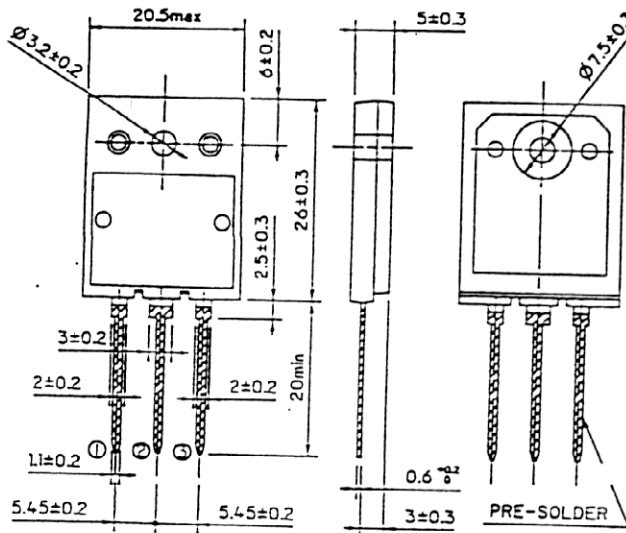

CONNECTION

- ① GATE
- ② COLLECTOR
- ③ EMITTER

2. Equivalent circuit

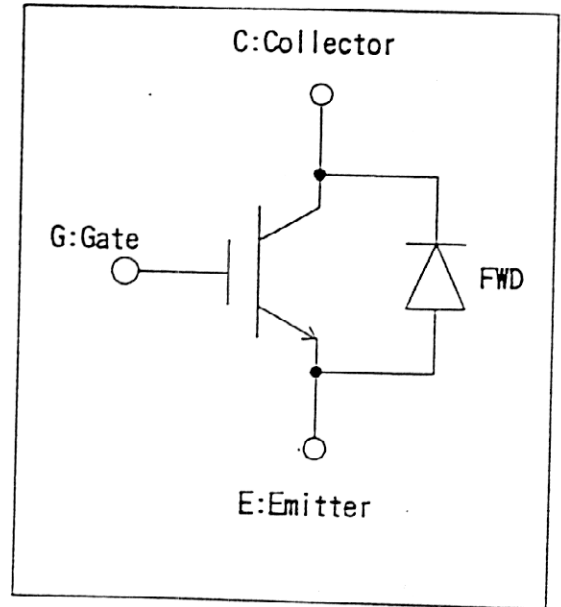

3. Absolute maximum ratings (Tc=25°C)

Items		Symbols	Ratings	Units
Collector-Emitter Voltage		V_{CES}	600	V
Gate-Emitter Voltage		V_{GES}	±22	V
Collector Current	DC	Tc=25 °C	I_{C25}	45 A
		Tc=110°C	I_{C110}	20 A
	1ms	Tc=25 °C	I_{cp}	152 A
IGBT Max. Power Dissipation		P_c	170	W
FWD Max. Power Dissipation		P_c	95	W
Operating Temperature		T_j	+ 150	°C
Storage Temperature		T_{stg}	-40 ~ +150	°C
Mounting Screw Torque		—	70	N · cm

Fuji Electric Co., Ltd.

DWG. NO.

MS5F4086

4/14

4. Electrical Characteristics (at Tc=25°C unless otherwise specified)

Items	Symbols	Characteristics			Conditions	Unit
		min.	typ.	max.		
Zero gate voltage Collector Current	I_{CES}			1.0	$V_{GE} = 0V$ $V_{CE} = 600V$	mA
Gate-Emitter leakage Current	I_{GES}			20	$V_{CE} = 0V$ $V_{GE} = \pm 22V$	μA
Gate-Emitter Threshold Voltage	$V_{GE(th)}$	5.5		8.5	$V_{CE} = 20V$ $I_C = 20mA$	V
Collector-Emitter Saturation Voltage	$V_{CE(sat)}$			3.0	$V_{GE} = 15V$ $I_C = 20A$	V
Input capacitance	C_{ies}		1300		$V_{GE} = 0V$	pF
Output capacitance	C_{oes}		300		$V_{CE} = 10V$	
Reverse transfer capacitance	C_{res}		70		$f = 1MHz$	
Switching Time	Turn-on time	t_{on}		1.2	$V_{CC} = 300V$ $I_C = 20A$ $V_{GE} = \pm 15V$ $R_G = 120\Omega$ (Half Bridge)	μs
		t_r		0.6		
	Turn-off time	t_{off}		1.0		
		t_f		0.35		
	Turn-on time	t_{on}	0.16		$V_{CC} = 300V$ $I_C = 20A$ $V_{GE} = +15V$ $R_G = 12\Omega$ (Half Bridge)	
		t_r	0.11			
	Turn-off time	t_{off}	0.30			
		t_f		0.35		
FWD forward voltage drop	V_F			3.0	$I_F = 20A$	V
Reverse recovery time	t_{rr}			0.3	$I_F = 20A, V_{GE} = -10V$ $V_R = 200V$ $di/dt = 100A/\mu s$	μs

5. Thermal resistance characteristics

Items	Symbols	Characteristics			Conditions	Unit
		min.	typ.	max.		
Thermal resistance	$R_{th(j-c)}$			0.73	IGBT	$^{\circ}C/W$
	$R_{th(j-c)}$			1.31	FWD	

Fuji Electric Co.,Ltd

DWG.NO.

MS5F4086

5/14

This material and the information herein is the property of Fuji Electric Co., Ltd. They shall be neither reproduced, copied, lent, or disclosed in any way whatsoever for the use of any third party nor used for the manufacturing purposes without the express written consent of Fuji Electric Co., Ltd.

Collector Current vs. Collector-Emitter Voltage
 $T_j = 125^\circ\text{C}$

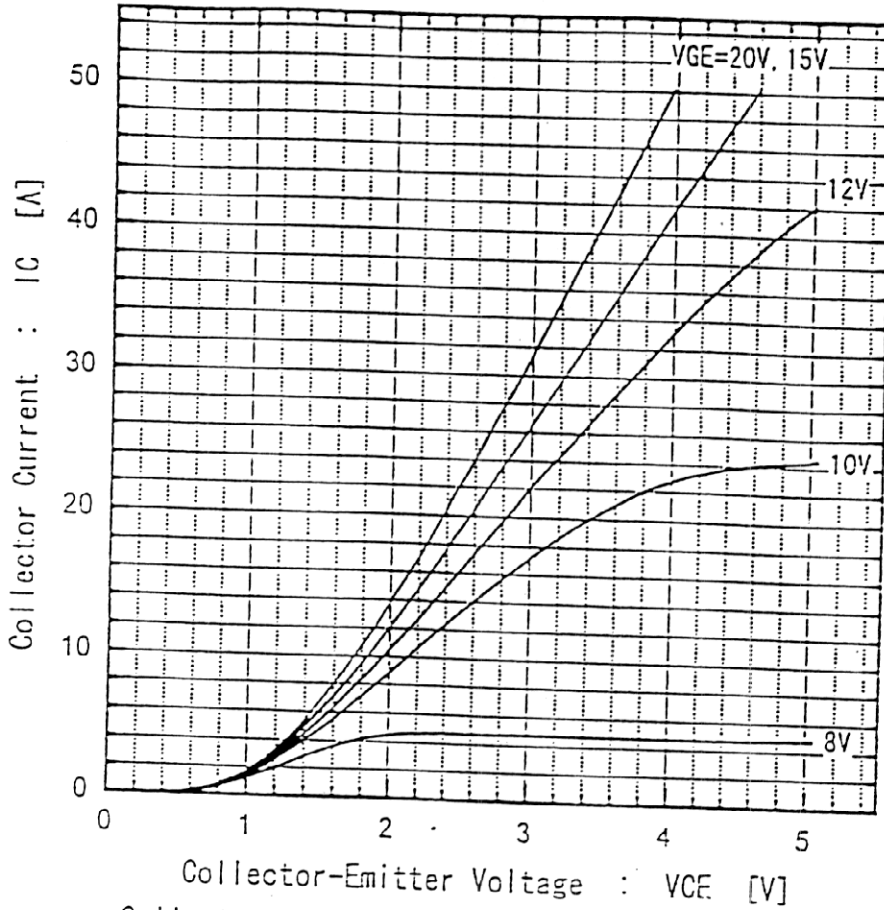

Collector Current vs. Collector-Emitter Voltage
 $T_j = 25^\circ\text{C}$

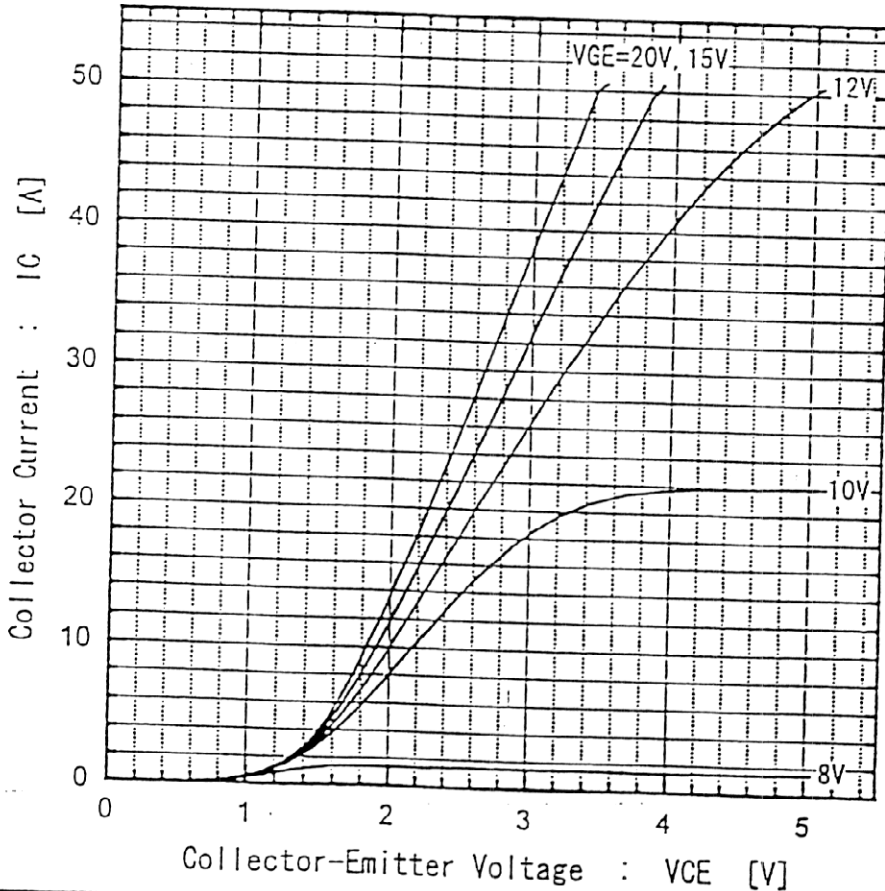

Fuji Electric Co., Ltd.

DWG. NO.

MS5 F 4086

6/14

Collector-Emitter Voltage vs Gate-Emitter Voltage
 $T_j=25^\circ\text{C}$

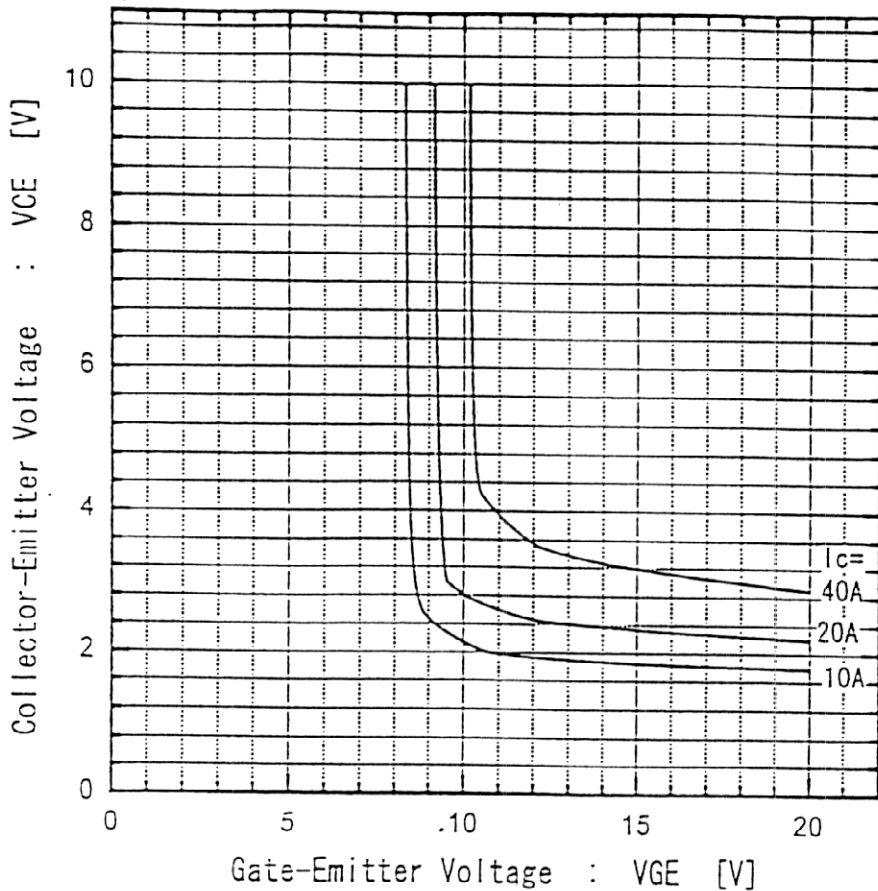

Collector-Emitter Voltage vs Gate-Emitter Voltage
 $T_j=125^\circ\text{C}$

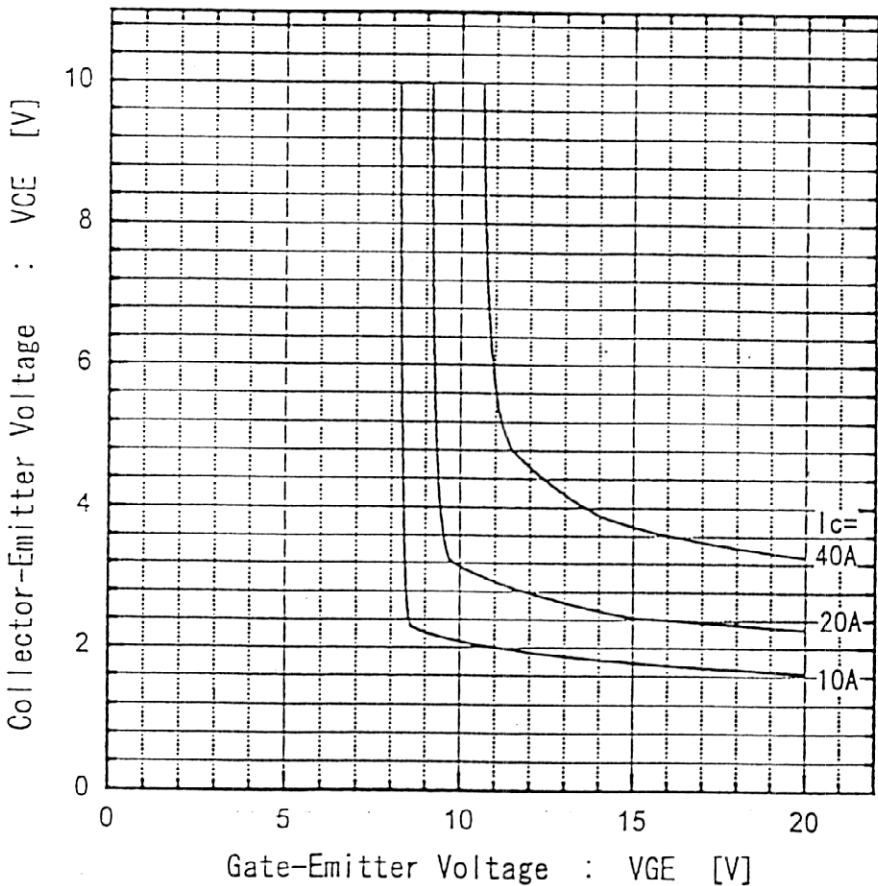

Fuji Electric Co. Ltd. They shall be neither reproduced, copied, lent, or disclosed in any way whatsoever for the use of any third party nor used for the manufacturing purposes without the express written consent of Fuji Electric Co., Ltd.

Fuji Electric Co., Ltd.

DWG. NO.

MS5 F 4086

7/14

Switching time vs. Collector current
 $V_{CC}=300V, R_G=12\Omega, V_{GE}=\pm 15V, T_j=25^\circ C$

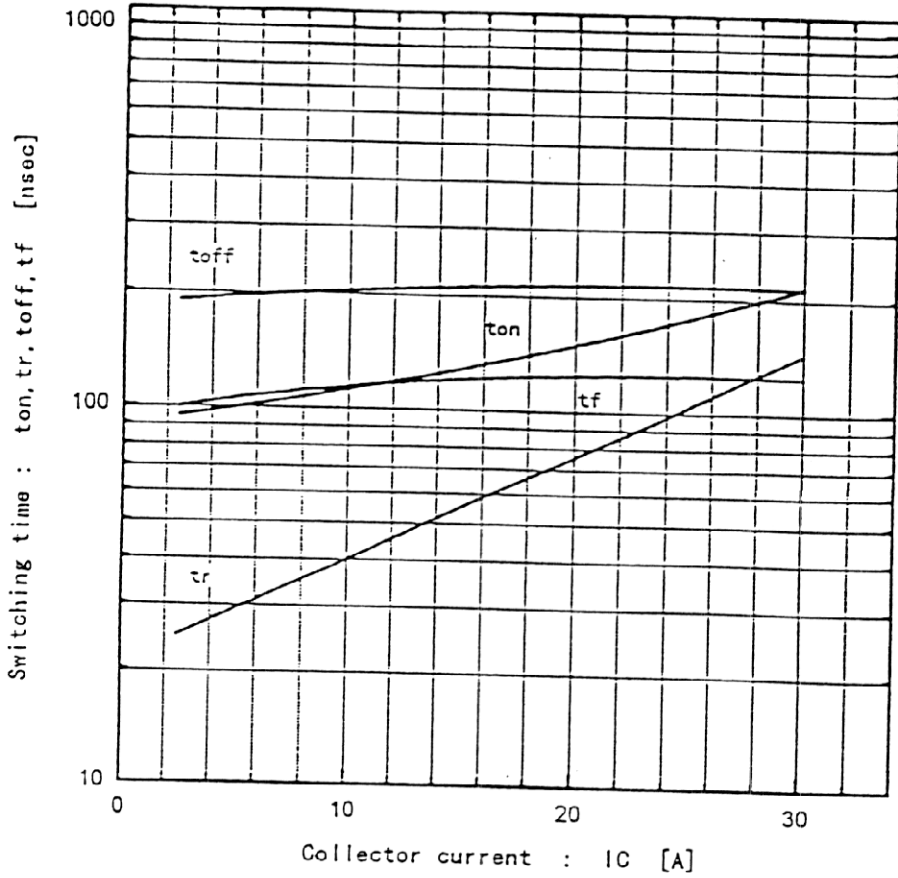

Switching time vs. Collector current
 $V_{CC}=300V, R_G=12\Omega, V_{GE}=\pm 15V, T_j=125^\circ C$

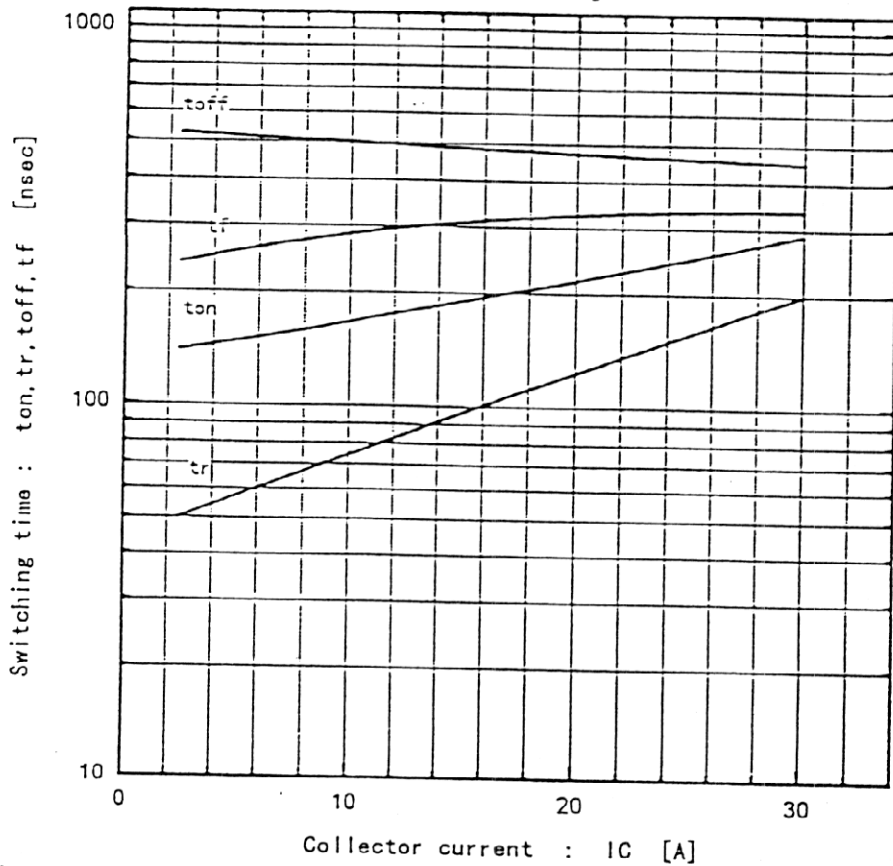

This material and the information herein is the property of Fuji Electric Co., Ltd. They shall be neither reproduced, copied, lent, or disclosed in any way whatsoever for the use of any third party nor used for the manufacturing purposes without the express written consent of Fuji Electric Co., Ltd.

Fuji Electric Co., Ltd.

DWG. NO.

MS5 F4086

8/14

This material and the information herein is the property of Fuji Electric Co., Ltd. They shall be neither reproduced, copied, lent, or disclosed in any way whatsoever for the use of any third party nor used for the manufacturing purposes without the express written consent of Fuji Electric Co., Ltd.

Switching time vs. RG
 $V_{cc}=300V, I_C=20A, V_{GE}=\pm 15V, T_j=25^\circ C$

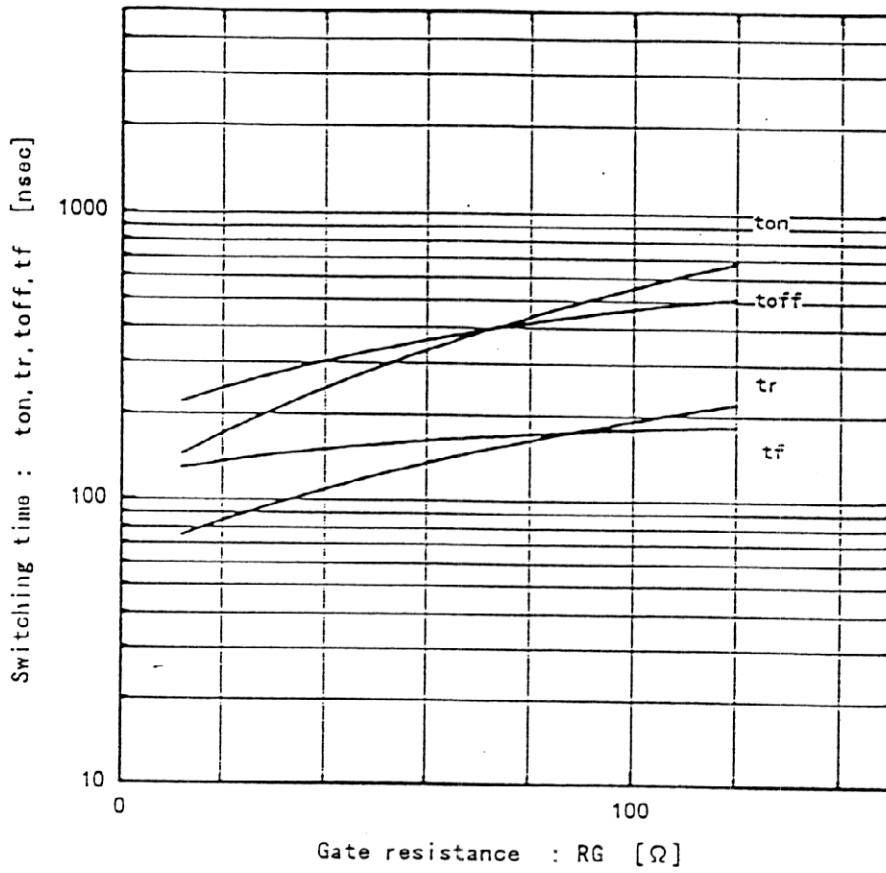

Switching time vs. RG
 $V_{cc}=300V, I_C=20A, V_{GE}=\pm 15V, T_j=125^\circ C$

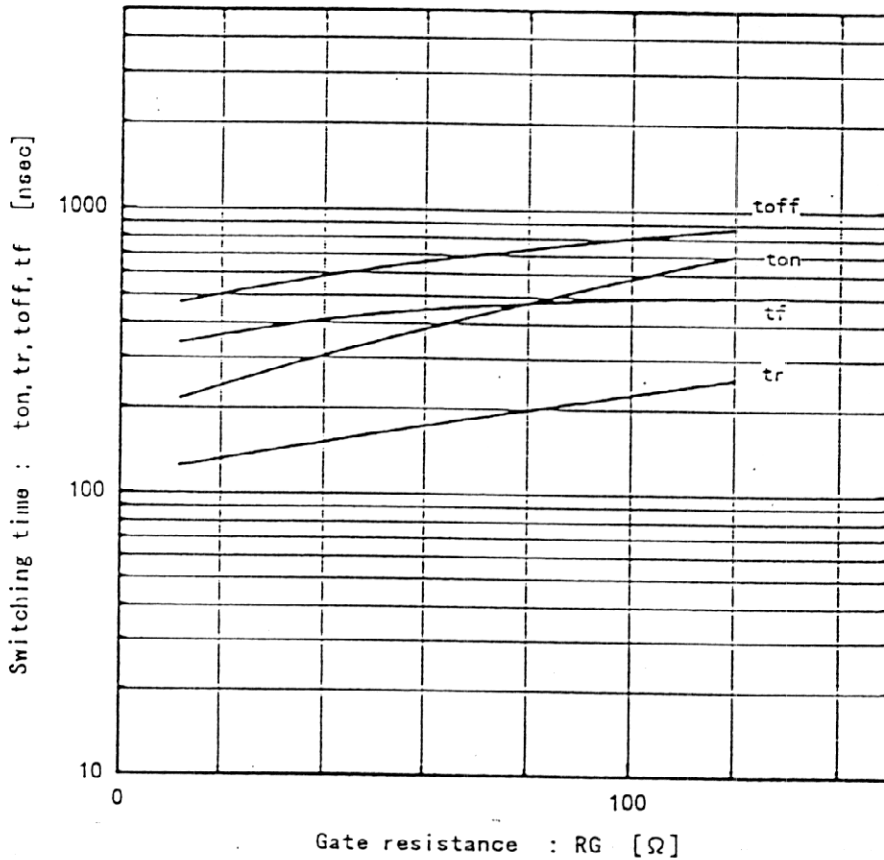

Fuji Electric Co., Ltd.

DWG. NO.

MS5 F 4086

9/14

This material and the information herein is the property of Fuji Electric Co., Ltd. They shall be neither reproduced, copied, lent, or disclosed in any way whatsoever for the use of any third party nor used for the manufacturing purposes without the express written consent of Fuji Electric Co., Ltd.

Dynamic input characteristics
 $T_j=25^\circ\text{C}$

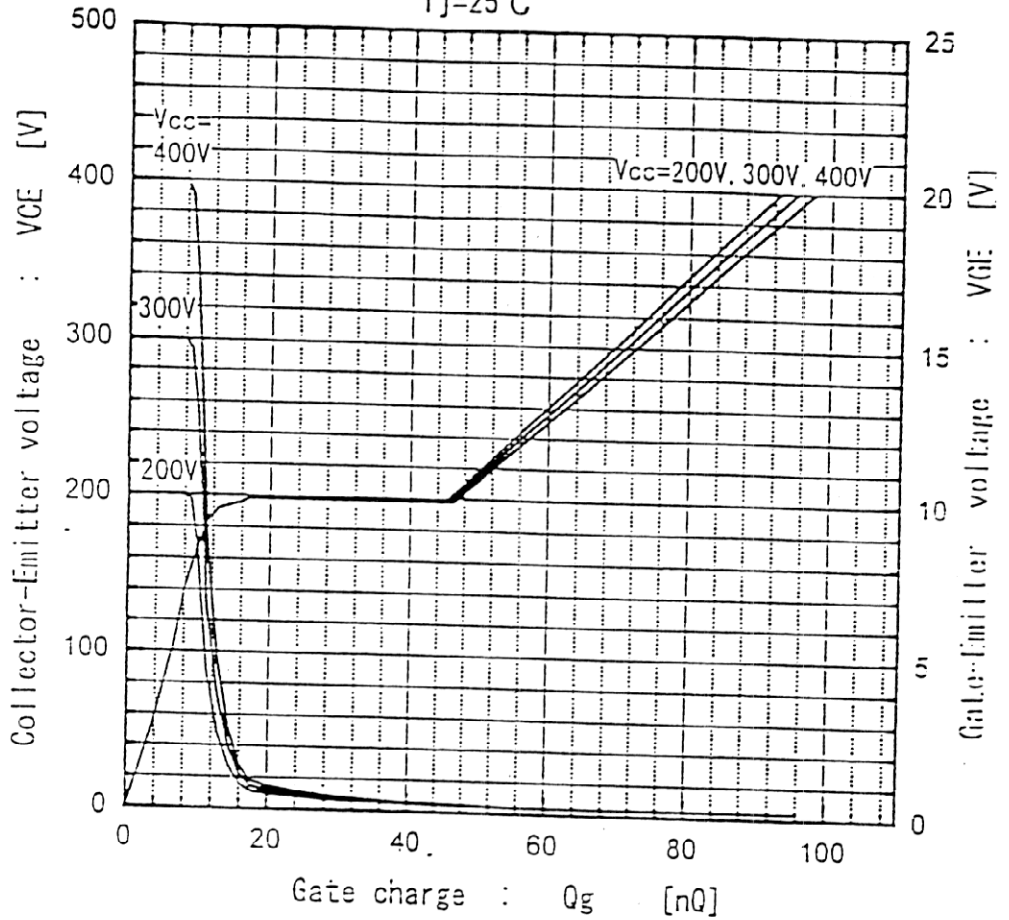

Capacitance vs. Collector-Emitter voltage
 $T_j=25^\circ\text{C}$

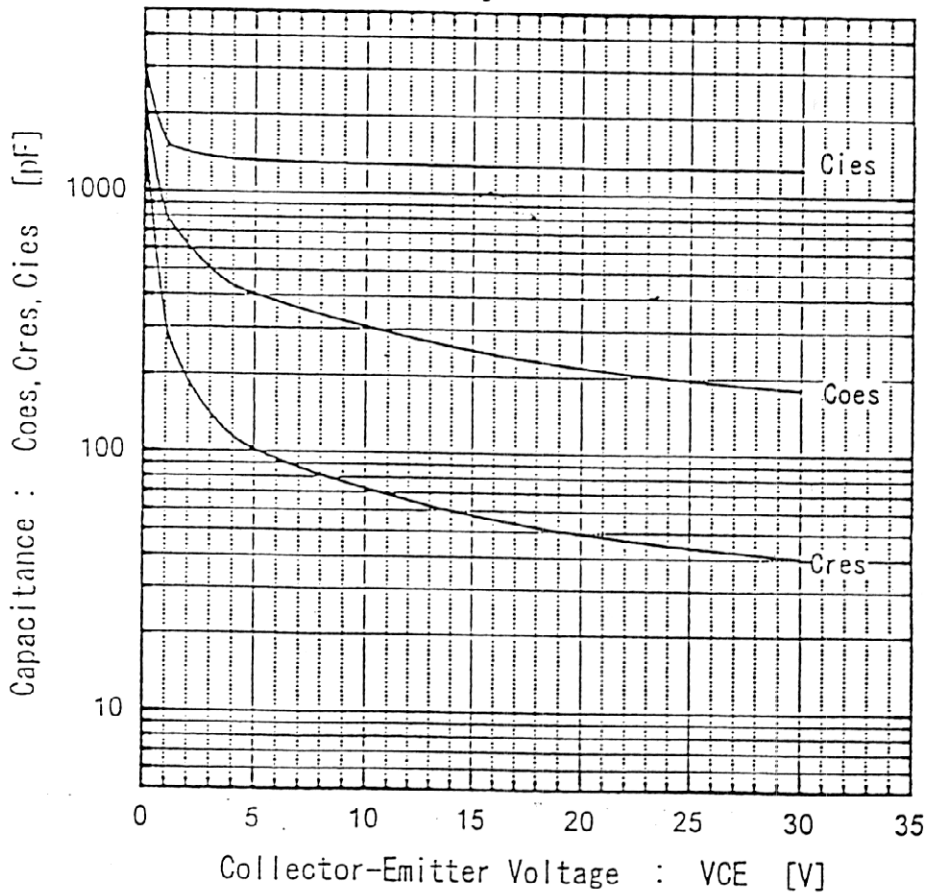

Fuji Electric Co., Ltd.

DWGNO.

MS5F4086

10/14

H04-004-03

This material and the information herein is the property of Fuji Electric Co. Ltd. They shall be neither reproduced, copied, lent, or disclosed in any way whatsoever for the use of third party nor used for the manufacturing purposes without the express written consent of Fuji Electric Co., Ltd.

Reverse Biased Safe Operating Area
 $+V_{GE}=15V, -V_{GE} \leq 15V, T_j \leq 125^\circ C, R_G \geq 12 \Omega$

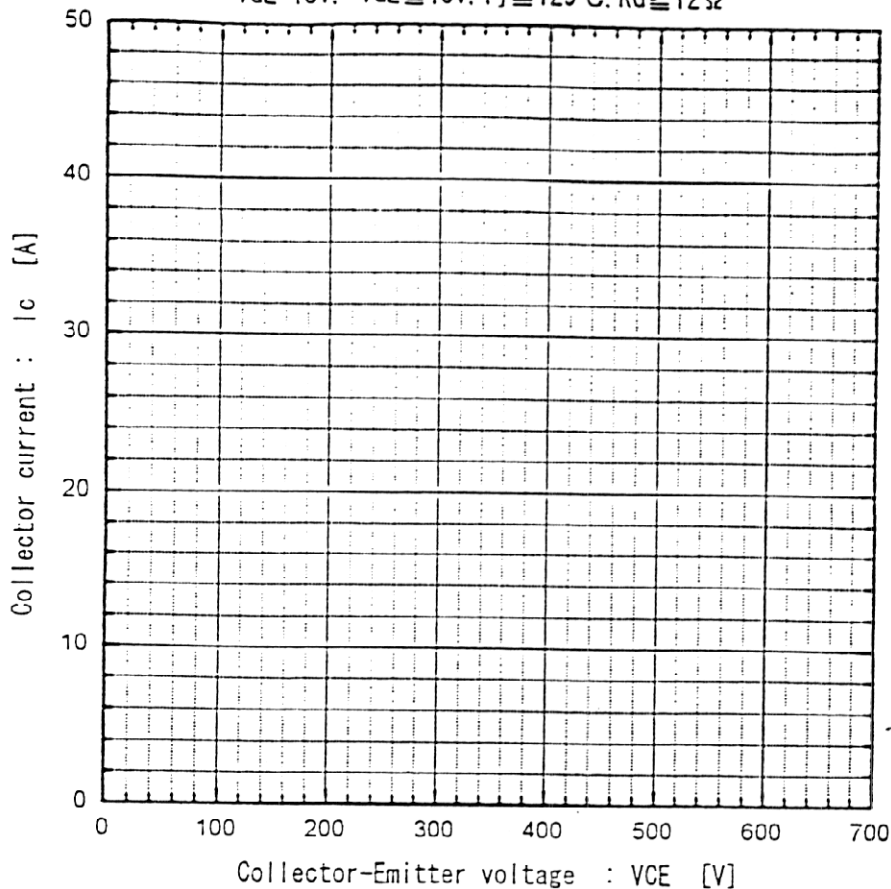

Typical short circuit capability
 $V_{CC}=400V, R_G=12 \Omega, T_j=125^\circ C$

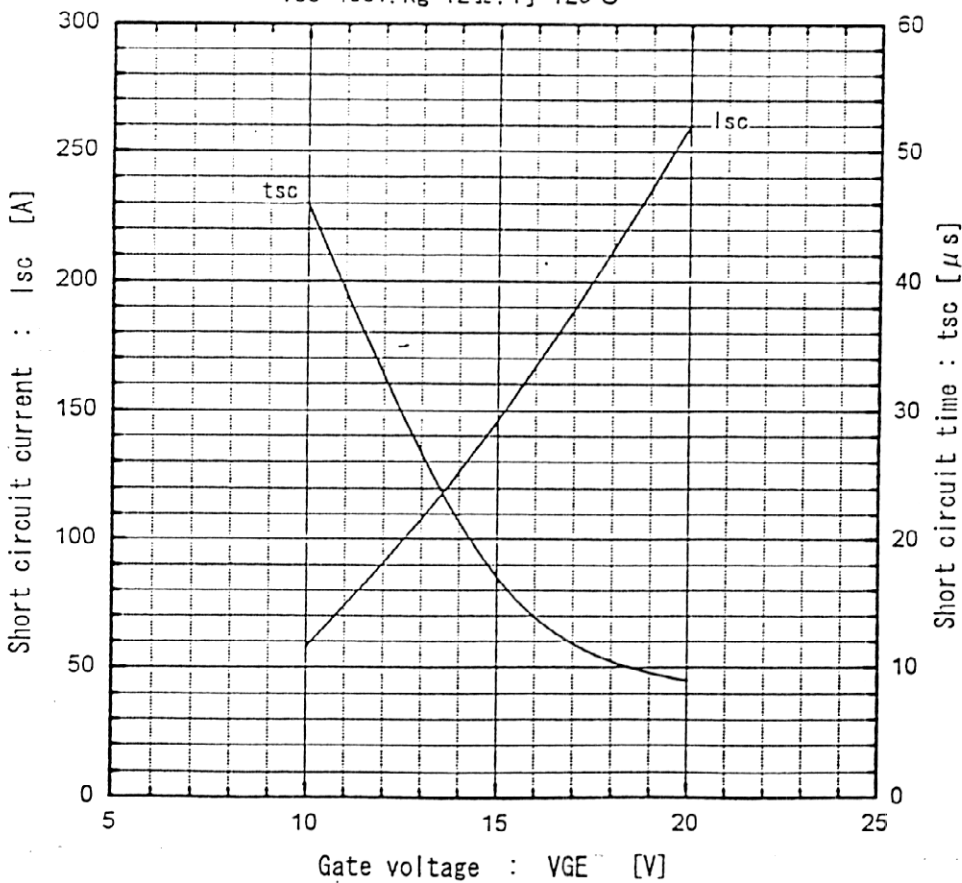

Fuji Electric Co., Ltd.

DWG. NO.

MS5 F 4086

11/14

Reverse recovery time vs. Forward current
 $V_R=200V, -di/dt=100A/\mu sec$

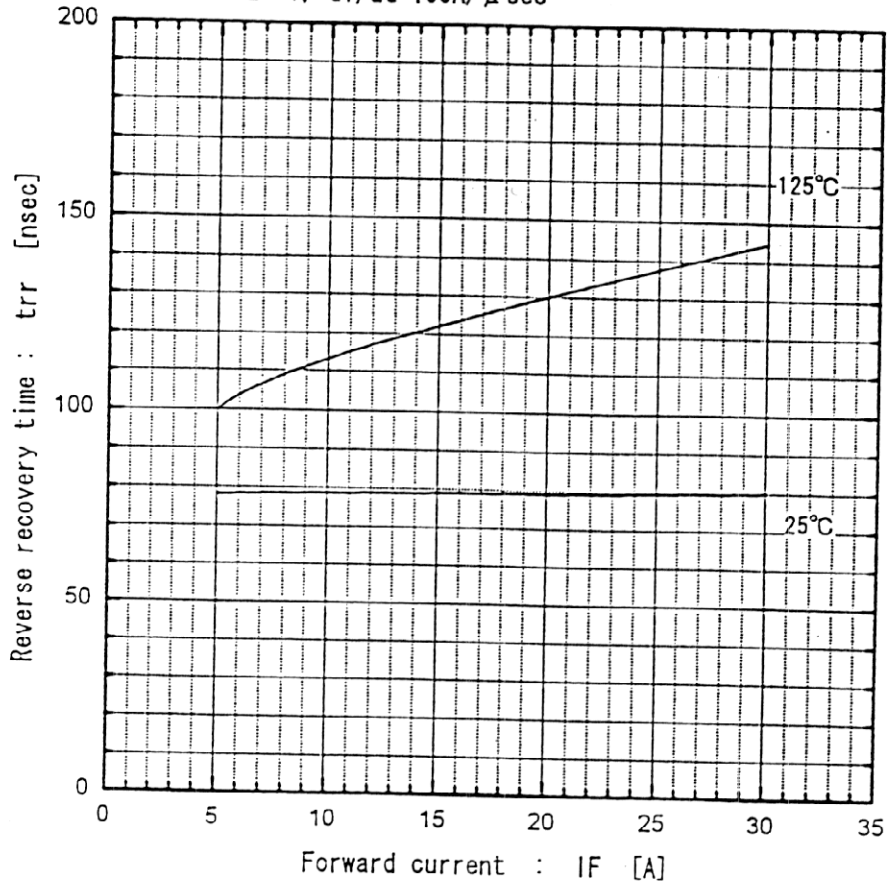

Reverse recovery current vs. Forward current
 $V_R=200V, -di/dt=100A/\mu sec$

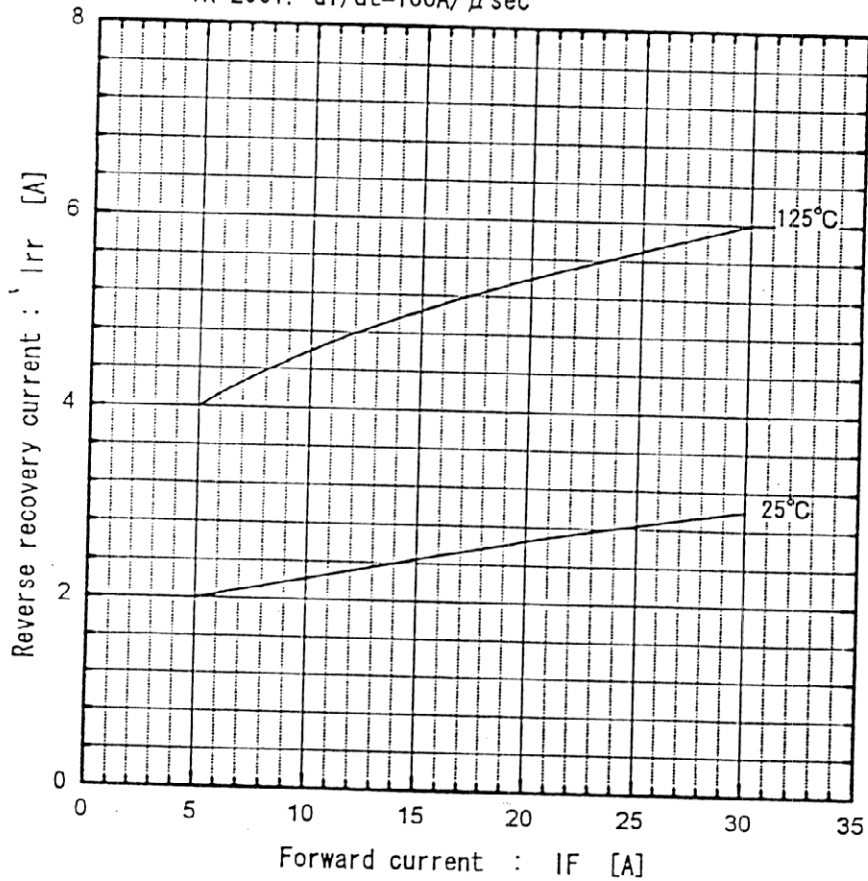

This material and the information herein is the property of Fuji Electric Co. Ltd. They shall be neither reproduced, copied, lent, or disclosed in any way whatsoever for the use of any third party nor used for the manufacturing purposes without the express written consent of Fuji Electric Co., Ltd.

Fuji Electric Co., Ltd.

DWG. NO.

MS5 F 4086

12/14

Forward voltage vs. Forward current

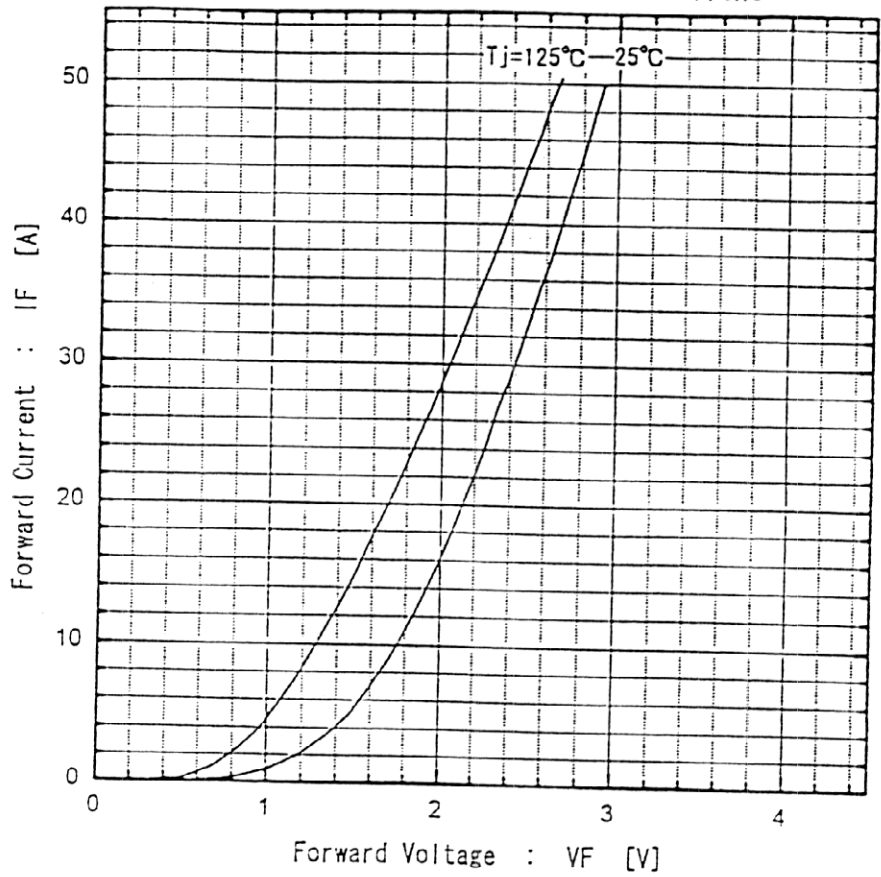

Reverse recovery characteristics vs. $-di/dt$
 $I_F=20A, T_j=125^\circ C$

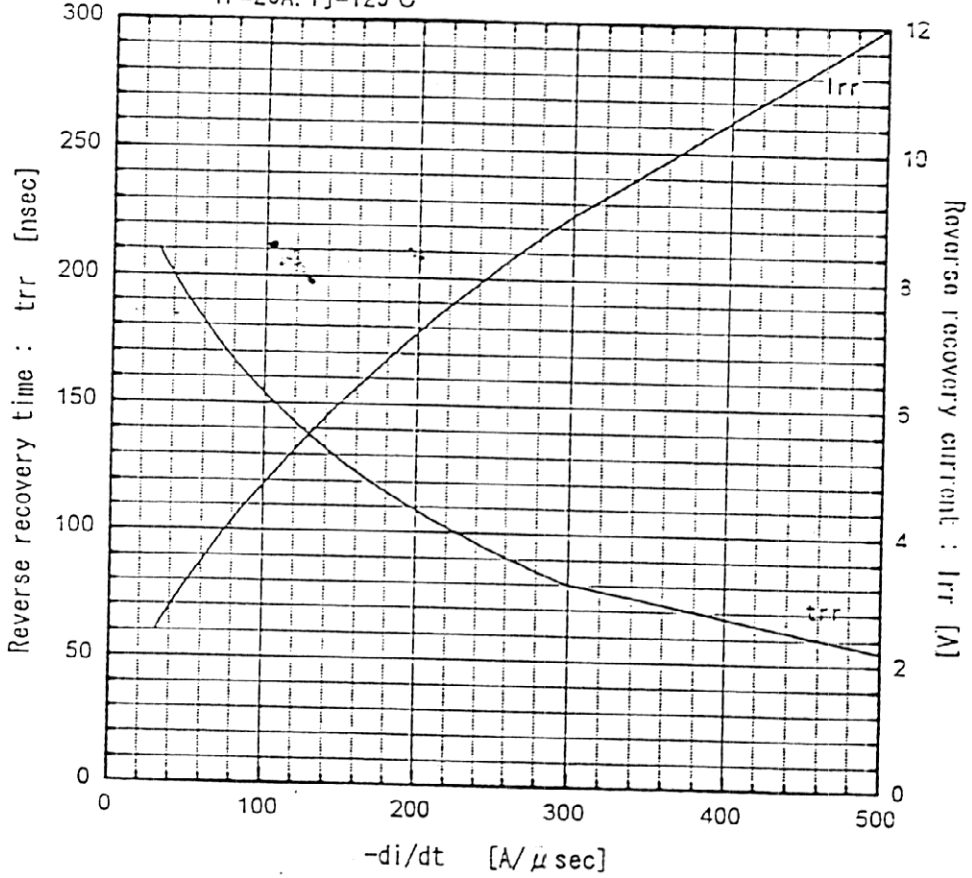

This material and the information herein is the property of Fuji Electric Co., Ltd. They shall be neither reproduced, copied, lent, or disclosed in any way whatsoever for the use of any third party nor used for the manufacturing purposes without the express written consent of Fuji Electric Co., Ltd.

Fuji Electric Co., Ltd.

DWG. NO.

MS5 F 4086

13/14

Transient thermal resistance

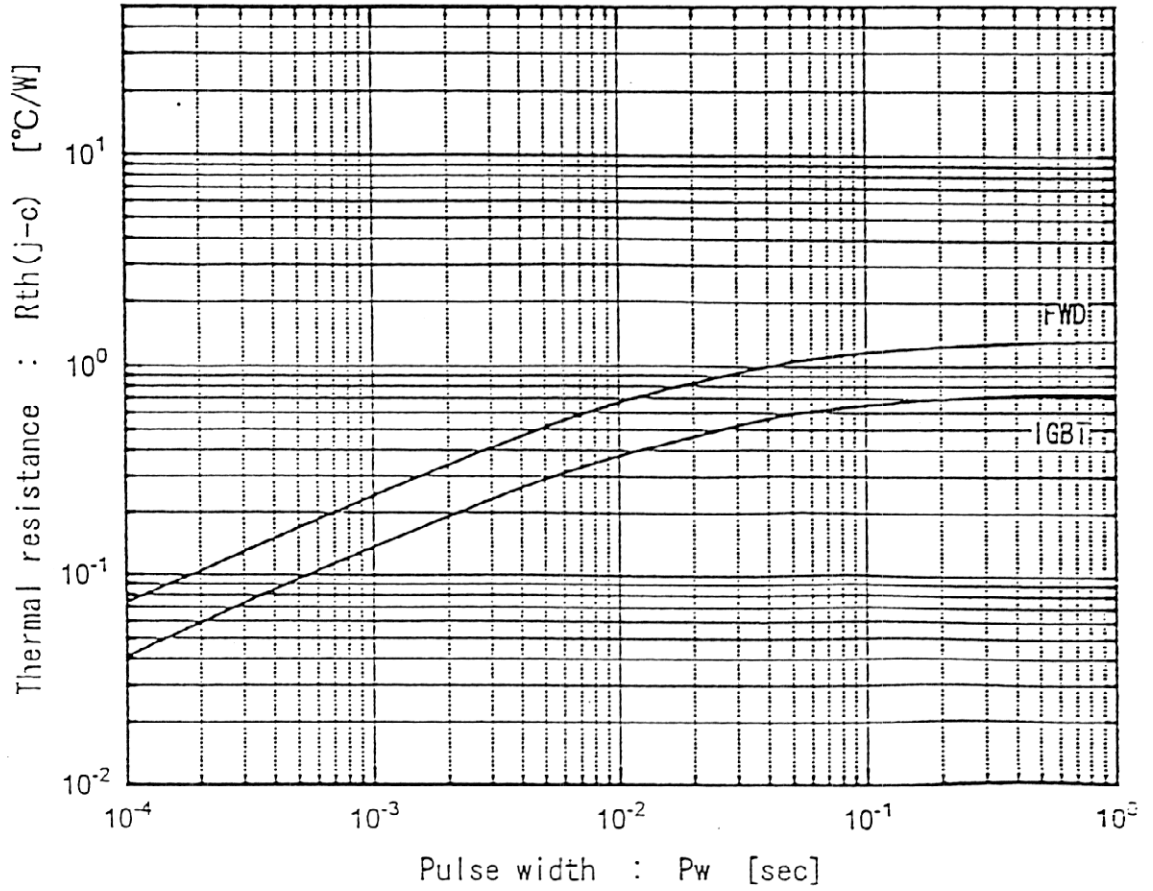

This material and the information herein is the property of Fuji Electric Co., Ltd. They shall be neither reproduced, copied, lent, or disclosed in any way whatsoever for the use of any third party nor used for the manufacturing purposes without the express written consent of Fuji Electric Co., Ltd.

Fuji Semiconductor, Inc. - P.O. Box 702708 - Dallas, TX 75370 - 972-733-1700 - www.fujjsemiconductor.com

Fuji Electric Co., Ltd.

DWG. NO.

MS5 F 4086

14/14

H04-004-03