

## Fuji Discrete Package IGBT

### ■ Features

- Square RBSOA
- Low Saturation Voltage
- Less Total Power Dissipation
- Minimized Internal Stray Inductance

### ■ Applications

- High Power Switching
- A.C. Motor Controls
- D.C. Motor Controls
- Uninterruptible Power Supply

### ■ Outline Drawing

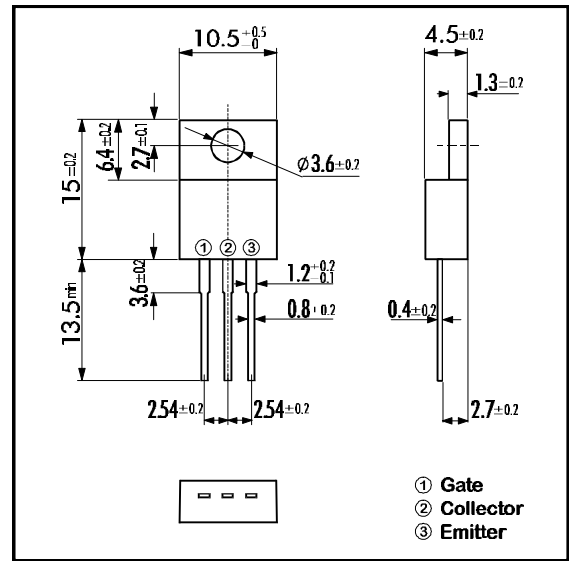

### ■ Maximum Ratings and Characteristics

#### • Absolute Maximum Ratings (T<sub>c</sub>=25°C)

Items	Symbols	Ratings	Units
Collector-Emitter Voltage	V <sub>CEs</sub>	600	V
Gate -Emitter Voltage	V <sub>GES</sub>	± 20	V
Collector Current	DC T <sub>c</sub> = 25°C	I <sub>C 25</sub>	13
	DC T <sub>c</sub> =100°C	I <sub>C 100</sub>	5
	1ms T <sub>c</sub> = 25°C	I <sub>C PULSE</sub>	52
IGBT Max. Power Dissipation	P <sub>C</sub>	50	W
Operating Temperature	T <sub>j</sub>	+150	°C
Storage Temperature	T <sub>stg</sub>	-40 ~ +125	°C
Mounting Screw Torque		40	Nm

### ■ Equivalent Circuit

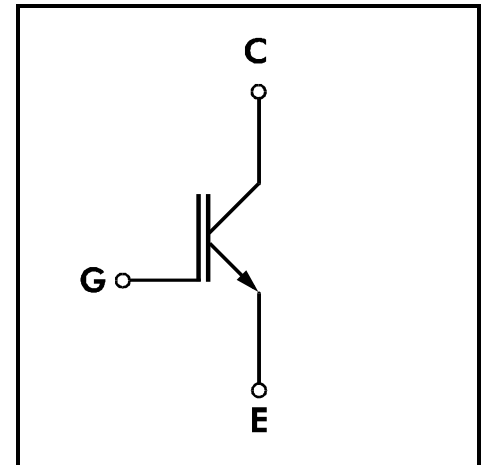

#### • Electrical Characteristics (at T<sub>j</sub>=25°C)

Items	Symbols	Test Conditions	Min.	Typ.	Max.	Units	
Zero Gate Voltage Collector Current	I <sub>CEs</sub>	V <sub>GE</sub> =0V V <sub>CE</sub> =600V			1.0	mA	
Gate-Emitter Leakage Current	I <sub>GES</sub>	V <sub>CE</sub> =0V V <sub>GE</sub> =± 20V			20	μA	
Gate-Emitter Threshold Voltage	V <sub>GE(th)</sub>	V <sub>GE</sub> =20V I <sub>C</sub> =5mA	5.5		8.5	V	
Collector-Emitter Saturation Voltage	V <sub>CE(sat)</sub>	V <sub>GE</sub> =15V I <sub>C</sub> =5A			3.0	V	
Input capacitance	C <sub>ies</sub>	V <sub>GE</sub> =0V		400		pF	
Output capacitance	C <sub>oes</sub>	V <sub>CE</sub> =10V		85			
Reverse Transfer capacitance	C <sub>res</sub>	f=1MHz		15			
Switching Time	Turn-on Time	t <sub>ON</sub>	V <sub>CC</sub> =300V			1.2	μs
		t <sub>r</sub>	I <sub>C</sub> =5A			0.6	
	Turn-off Time	t <sub>OFF</sub>	V <sub>GE</sub> =±15V			1.0	
		t <sub>f</sub>	R <sub>G</sub> =330Ω			0.35	
	Turn-on Time	t <sub>ON</sub>	V <sub>CC</sub> =300V		0.16		μs
		t <sub>r</sub>	I <sub>C</sub> =5A		0.11		
t <sub>OFF</sub>		V <sub>GE</sub> =+15V		0.30			
t <sub>f</sub>		R <sub>G</sub> =33Ω			0.35		

#### • Thermal Characteristics

Items	Symbols	Test Conditions	Min.	Typ.	Max.	Units
Thermal Resistance	R <sub>th(j-c)</sub>				2.50	°C/W

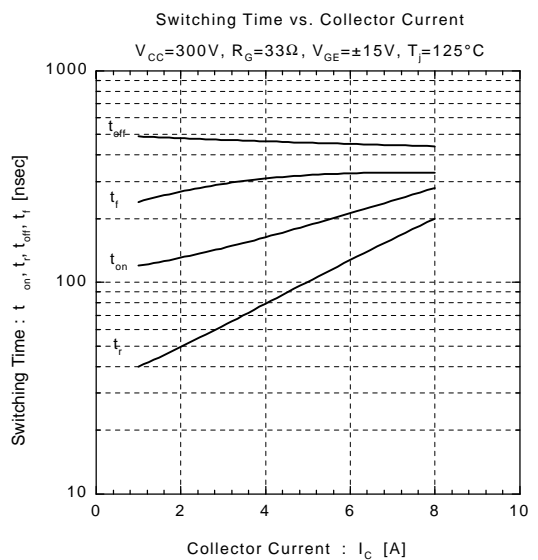
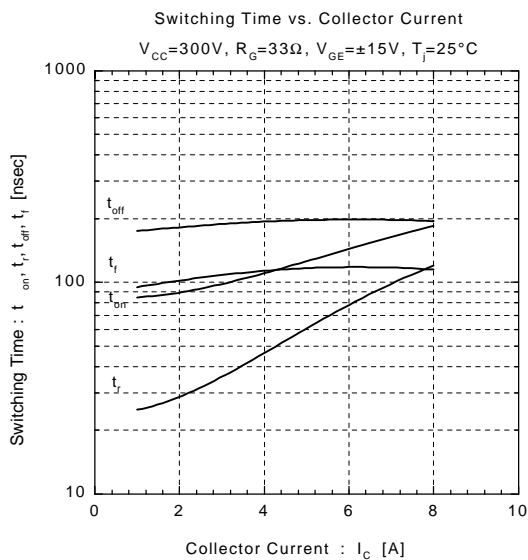
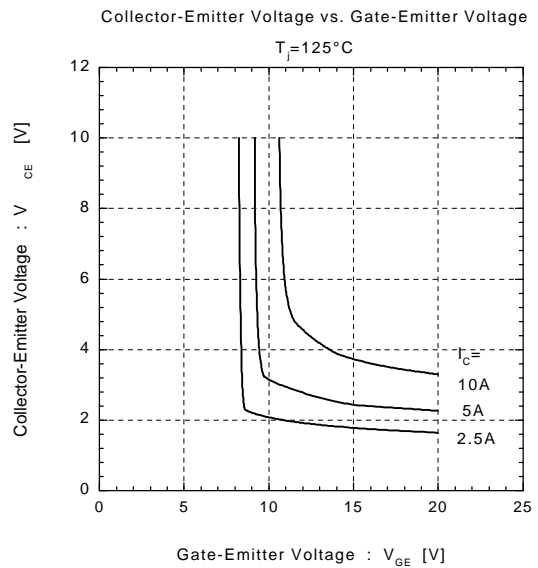
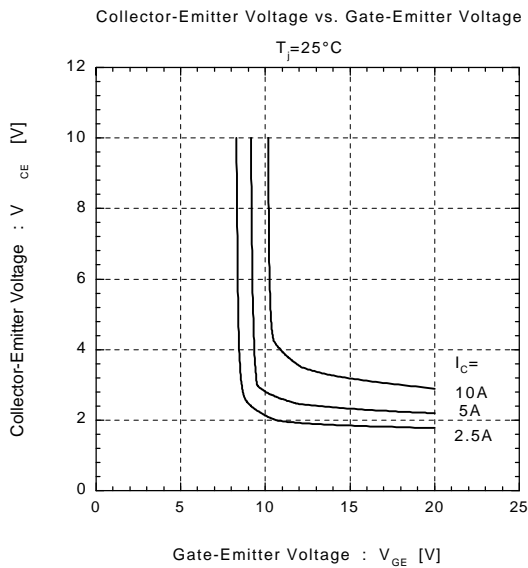
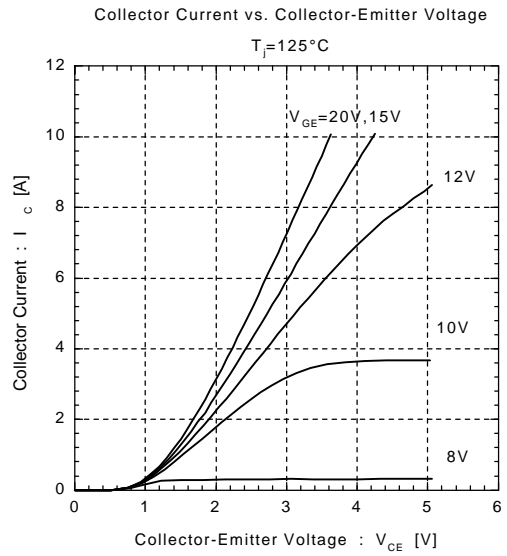
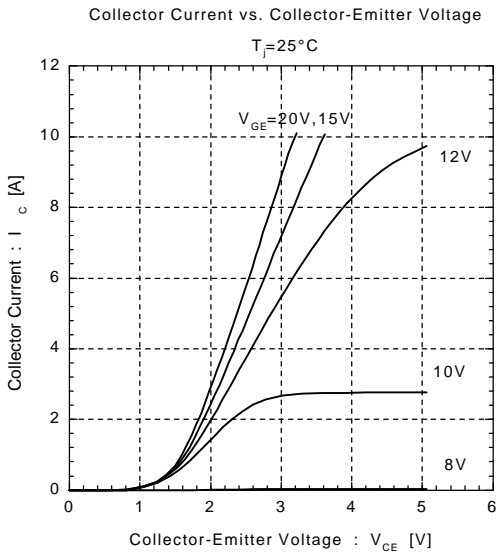

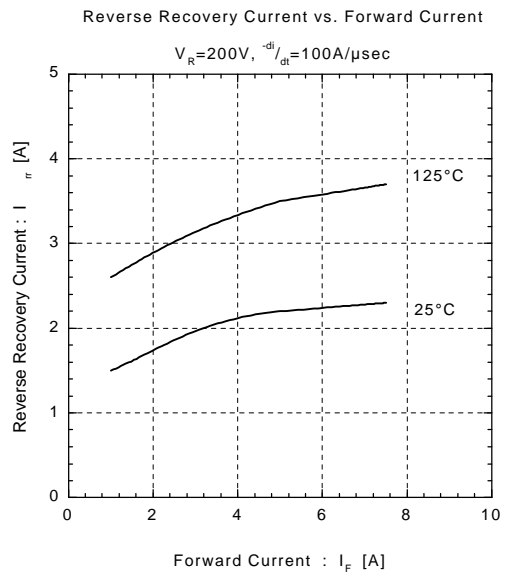
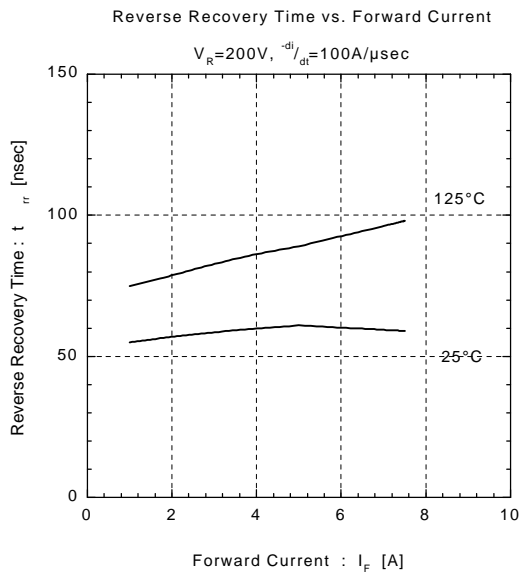
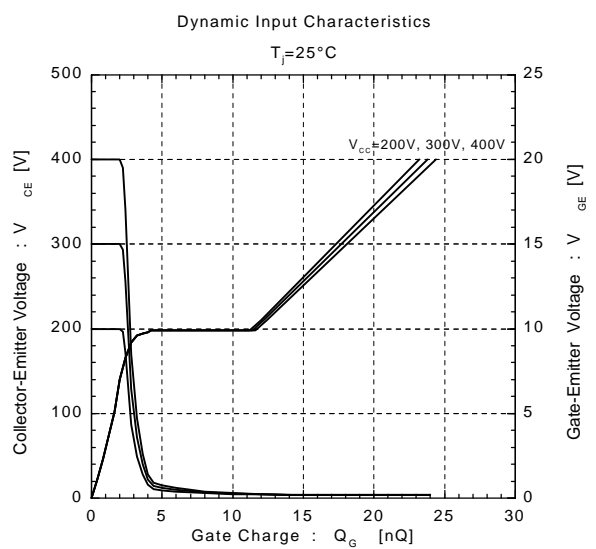
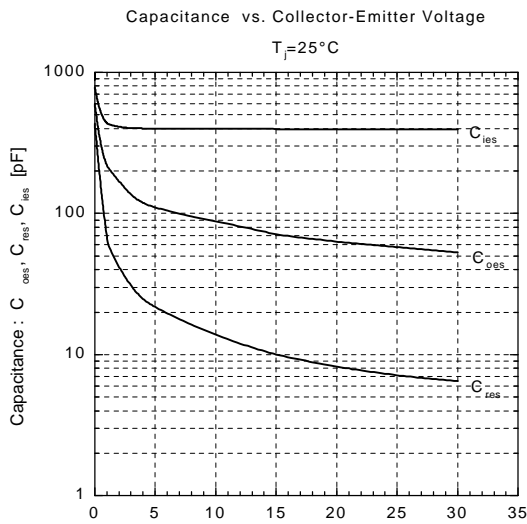
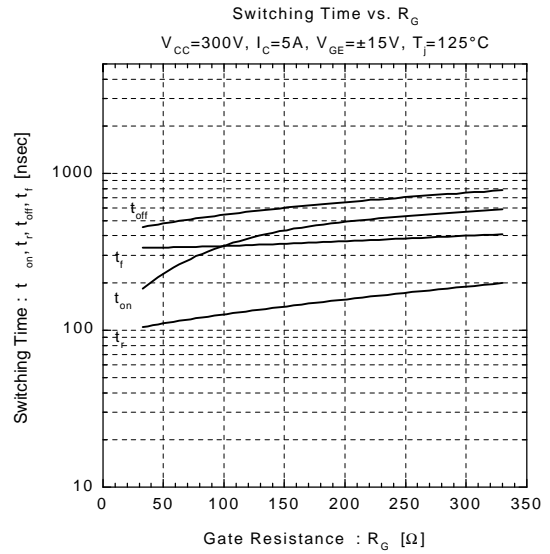
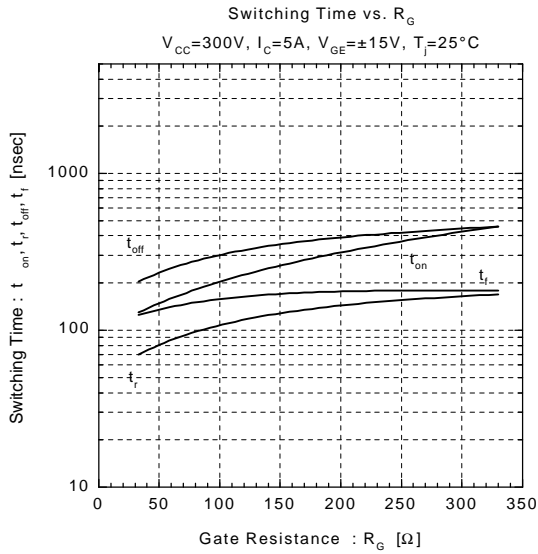

Reverse Biased Safe Operating Area  
 $+V_{GE}=15V, -V_{GE}\leq 15V, T_J\leq 125^\circ C, R_G\geq 33\Omega$

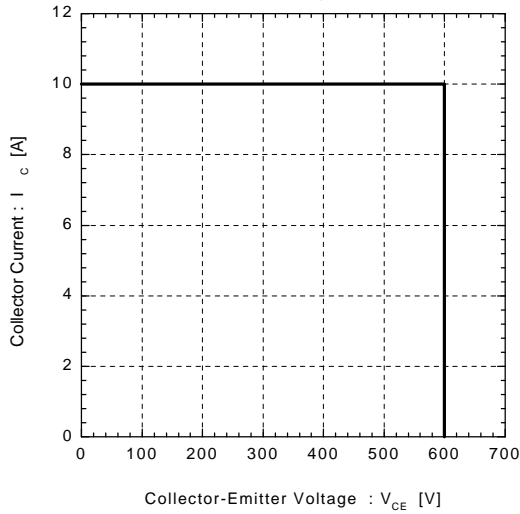

Typical Short Circuit Capability  
 $V_{CC}=400V, R_G=33\Omega, T_J=125^\circ C$

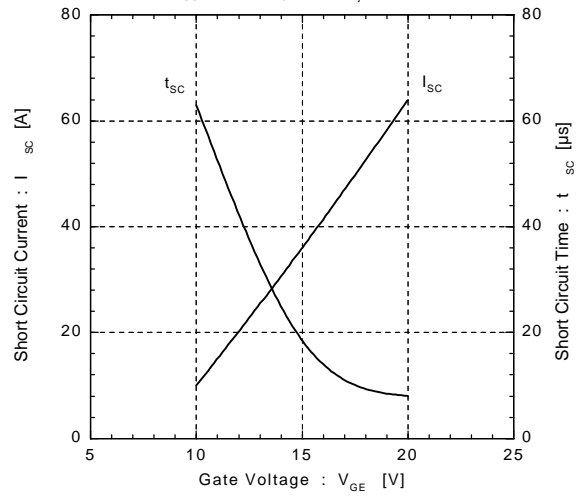

Forward Voltage vs. Forward Current

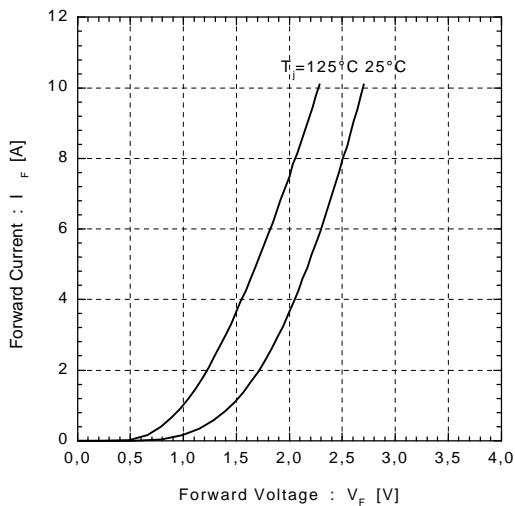

Reverse Recovery Characteristics vs.  $-di/dt$   
 $I_F=5A, T_J=125^\circ C$

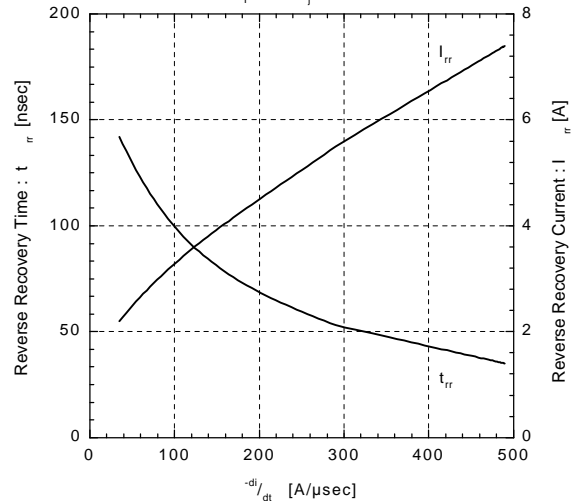

Transient Thermal Resistance

