

SPECIFICATION

(TENTATIVE)

Product Name : IGBT Module (Power Integrated Module)

Type Name : 7MBR10PE120

Spec. No. : **MT6M1918**

This material and the information herein is the property of Fuji Electric Co. Ltd. They shall be neither reproduced, copied, lent, or disclosed in any way whatsoever for the use of any third party nor used for the manufacturing purposes without the express written consent of Fuji Electric Co. Ltd.

a) Changed Ic, Icp, - Ic, Vce(sat), - Vce, Avg-29-97 Y. Arita, Miyamoto

Fuji Electric Co., Ltd. (Matsumoto Factory)

This specification is subject to change without notice.

	DATE	NAME	APPROVED	Fuji Electric Co., Ltd.	
DRAWN	Jun - 23 - 97	Y. Arita	S. K.	MT6M1918	1/5
CHECKED	June - 23 - 97	S. Miyamoto			a
REVISIONS					

7 M B R 1 0 P E 1 2 0

(TENTATIVE)

1. Outline Drawing

Unit : mm

*Isolation Voltage (Terminal to Case) : AC 2500V 1 minute

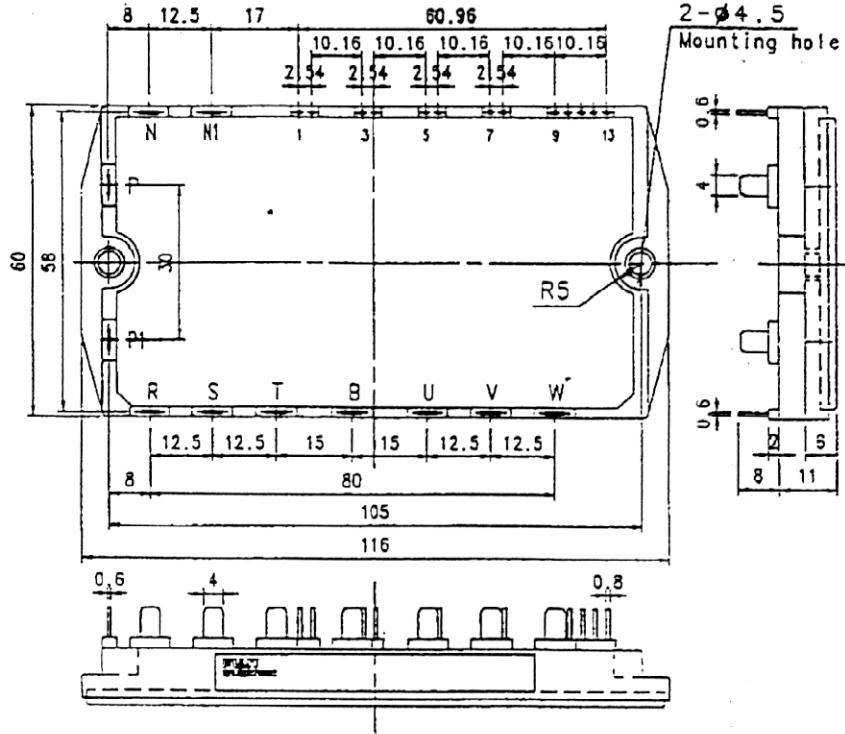

This material and the information herein is the property of Fuji Electric Co. Ltd. They shall be neither reproduced, copied, lent, or disclosed in any way whatsoever for the use of any third party nor used for the manufacturing purposes without the express written consent of Fuji Electric Co., Ltd.

2. Equivalent Circuit of Module

[Converter] [Brake] [Inverter]

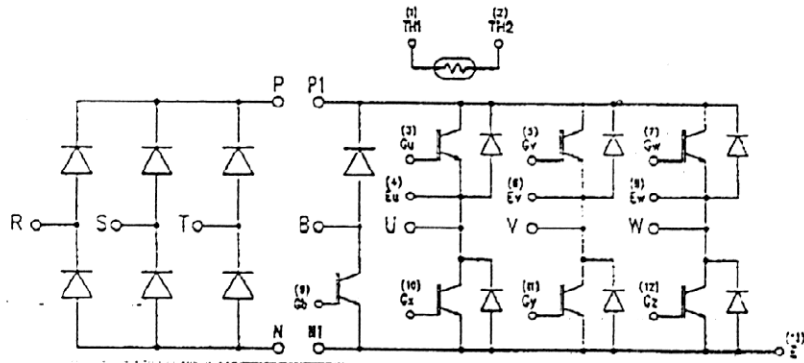

*This specification is changed without notes.

Fuji Electric Co., Ltd.

DWG. NO.

MT6M1918

3/5

a

3. Absolute Maximum Ratings (Tc=25°C unless without specified)

Items		Symbols	Conditions	Maximum Ratings	Units
Inverter	Collector-Emitter Voltage	V _{CES}	—	1200	V
	Gate-Emitter Voltage	V _{GES}	—	±20	V
	Collector Current	I _C	Continuous ⊗ 25 / 80°C	15/10 ⊗	A
		I _{CP}	1ms 25 / 80°C ⊗	30/20 ⊗	A
		-I _C	25 / 80°C ⊗	15/10 ⊗	A
Collector Power Dissipation	P _C	1 device	100	W	
Brake	Collector-Emitter Voltage	V _{CES}	—	1200	V
	Gate-Emitter Voltage	V _{GES}	—	±20	V
	Collector Current	I _C	Continuous ⊗ 25 / 80°C	15/10 ⊗	A
		I _{CP}	1ms 25 / 80°C ⊗	30/20 ⊗	A
	Collector power Dissipation	P _C	1 device	100	W
	Repetitive peak Reverse Voltage	V _{RRM}	—	1200	V
Converter	Repetitive Peak Reverse Voltage	V _{RRM}	—	1600	V
	Average Output Current	I _O	—	10	A
	Surge Current (Non-Repetitive)	I _{FSM}	Tj=150°C, 8.3ms half sine wave	162	A
	I ² t (Non-Repetitive)	I ² t	Tj=150°C	110	A ² s
Operating Junction Temperature		Tj		+ 150	°C
Storage Temperature		Tstg		-40 ~ +125	°C
Isolation Voltage		Viso	AC : 1 minute	AC 2500	V
Mounting Screw Torque (*1)				1.7	N · m

Note : (*1) Recommendable Value : 1.3 ~ 1.7 N · m (M4)

This material and the information herein is the property of Fuji Electric Co., Ltd. They shall be neither reproduced, copied, lent, or disclosed in any way whatsoever for the use of any third party or used for the manufacturing purposes without the express written consent of Fuji Electric Co., Ltd.

Fuji Electric Co., Ltd.

DWG. NO.

MT6M1918

3/5

Q

4. Electrical Characteristics (Tj=25°C unless without specified)

Characteristics		Symbols	Conditions	min.	max.	Units
Inverter	Zero gate voltage collector current	I _{CES}	V _{CE} =1200V V _{GE} = 0V		1.0	mA
	Gate-emitter leakage current	I _{GES}	V _{CE} = 0V V _{GE} =±20V		200	nA
	Gate-emitter threshold voltage	V _{GE(th)}	V _{CE} =20V I _C =10mA	6.0	9.0	V
	Collector-emitter saturation Voltage	V _{CE(sat)}	V _{GE} =15V I _C =10A		3.3	V
	Collector-Emitter Voltage	-V _{CE}	-I _C =15A		3.3	
	Input capacitance	C _{ies}	V _{GE} =0V V _{CE} =10V f=1MHz		1000 (typ.)	pF
	Switching Time	ton	V _{CC} = 600V I _C = 10A V _{GE} =±15V R _G =120Ω		1.2	μs
		tr			0.6	
		toff			1.0	
		tf			0.3	
Reverse Recovery Time of FRD	trr	I _F = 10A		350	ns	
Brake	Zero gate voltage collector current	I _{CES}	V _{CEs} =1200V V _{GE} = 0V		1.0	mA
	Gate-emitter leakage current	I _{GES}	V _{CE} = 0V V _{GE} =±20V		200	nA
	Collector-emitter Saturation Voltage	V _{CE(sat)}	I _C = 10A V _{GE} =15V		3.3	V
	Switching Time	ton	V _{CC} = 600V I _C = 10A V _{GE} =±15V R _G =120Ω		1.2	μs
		tr			0.6	
		toff			1.0	
		tf			0.3	
Reverse Current	I _{RRM}	V _R =1200V		1	mA	
Reverse Recovery Time	trr			350	ns	

This material and the information herein is the property of Fuji Electric Co., Ltd. They shall be neither reproduced, copied, lent, or disclosed in any way whatsoever for the use of any third party nor used for the manufacturing purposes without the express written consent of Fuji Electric Co., Ltd.

This material and the information herein is the property of Fuji Electric Co., Ltd. They shall be neither reproduced, copied, lent, or disclosed in any way whatsoever for the use of any third party, nor used for the manufacturing purposes without the express written consent of Fuji Electric Co., Ltd.

Characteristics		Symbols	Conditions	min.	max.	Units
Converter	Forward Voltage	V_{FM}	$I_F = 10A$		1.5	V
	Reverse Current	I_{RRM}	$V_R = 1600V$		1	mA
Thermistor	Resistance	R	$T_j = 25^\circ C$	5 (typ.)		k Ω
	B value	B	$T_j = 25/50^\circ C$	3375 (typ.)		K

5. Thermal Characteristics

Characteristics	Symbols	Conditions	min.	max.	Units
Thermal Resistance (1 device)	$R_{th(j-c)}$	Inverter IGBT		1.25	$^\circ C/W$
		Inverter FRD		3.71	
		Brake IGBT		1.25	
		Converter Diode		2.61	
Contact Thermal Resistance	$R_{th(c-f)}$	With Thermal Compound	(typ) 0.05		

Fuji Electric Co., Ltd.

DWG. NO.

MT 6M1918

5/5

a